



UNG100-12 (12V100Ah)



UNG100-12 is GEL Deep cycle battery, with 12 years floating design life, superiorly designed for frequent cyclic discharge applications under extreme temperature. By using strong grid to insure reliable performance under frequent cyclic discharge use. 400 cycles could be available at 100% DOD. Offering extra-durable cyclic performance, high efficiency of recovery, that is more suitable for solar, mobility, E-toll, marine, deep discharge UPS etc.

Specification

Cells Per Unit	6
Voltage Per Unit	12
Capacity	100Ah@20hr-rate to 1.75V per cell @25°C
Weight	Approx. 30.0 Kg
Max. Discharge Current	1000 A (5 sec)
Internal Resistance	Approx. 7.5 mΩ
Operating Temperature Range	Discharge: -40°C~60°C Charge:-20°C~50°C Storage: -40°C~60°C
Normal Operating Temperature Range	25°C ± 5°C
Float charging Voltage	13.6to 13.8 VDC/unit Average at 25°C
Recommended Maximum Charging Current Limit	20A
Equalization and Cycle Service	14.2 to 14.4VDC/unit Average at 25°C
Self Discharge	Valve Regulated Lead Acid (VRLA) batteries can be stored for more than 6 months at 25°C. Self-discharge ratio less than 3% per month at 25°C. Please charge batteries before using.
Terminal	Terminal F5/F12
Container Material	A.B.S. (UL94-HB), Flammability resistance of UL94-V1 can be available upon request.

Dimensions

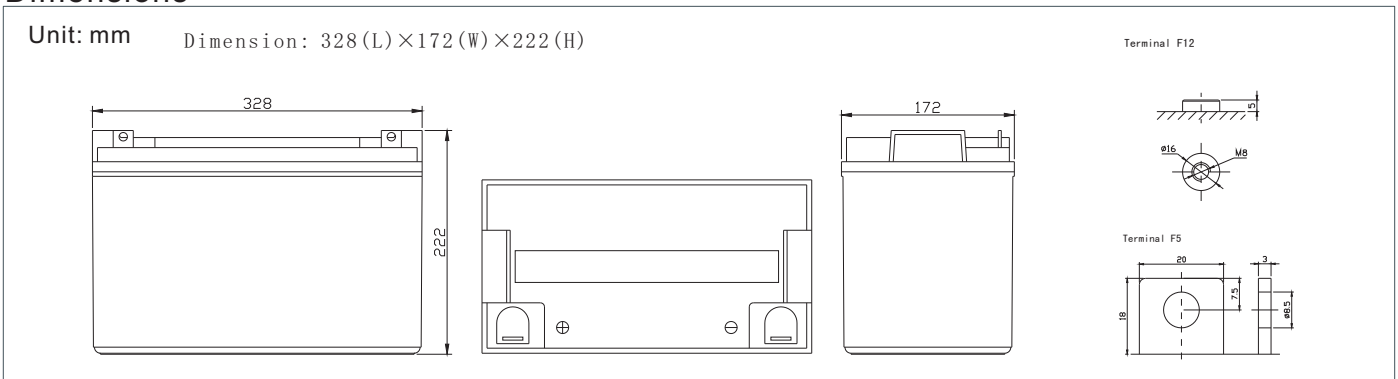

Constant Current Discharge Characteristics: A (25°C)

F.V/Time	5MIN	10MIN	15MIN	30MIN	1HR	2HR	3HR	4HR	5HR	8HR	10HR	20HR
9.60V	251.5	187.3	146.6	96.38	56.49	33.78	23.33	19.32	16.27	11.11	9.22	4.92
10.0V	244.2	178.2	143.6	94.79	56.23	33.53	23.24	19.23	16.17	11.02	9.13	4.83
10.2V	237.0	171.9	141.3	93.95	55.70	33.27	23.06	19.14	16.08	10.93	9.04	4.74
10.5V	215.3	160.5	136.1	94.15	55.18	33.02	22.97	18.97	15.89	10.84	8.95	4.65
10.8V	196.6	148.1	126.9	93.43	53.88	32.43	22.34	18.52	15.60	10.66	8.86	4.56
11.1V	169.8	133.9	115.2	88.31	51.19	30.99	21.36	17.62	14.93	10.21	8.60	4.29

Constant Power Discharge Characteristics: W (25°C)

F.V/Time	5MIN	10MIN	15MIN	30MIN	1HR	2HR	3HR	4HR	5HR	8HR	10HR	20HR
9.60V	2653	1995	1598	1081	652.7	398.2	277.6	230.3	194.1	132.7	110.1	58.97
10.0V	2601	1934	1572	1069	651.2	396.1	277.7	230.0	193.6	132.1	109.5	57.95
10.2V	2571	1883	1554	1072	646.1	393.7	276.5	229.5	192.9	131.2	108.5	56.87
10.5V	2368	1774	1500	1075	640.3	390.8	275.4	227.4	190.6	130.1	107.4	55.80
10.8V	2182	1654	1403	1068	628.5	385.8	267.9	222.2	187.2	127.9	106.4	54.73
11.1V	1939	1513	1277	1015	601.6	371.5	256.3	211.5	179.1	122.5	103.2	51.51

All mentioned values are average values.

UNG100-12

12V100Ah



Life characteristics of cyclic use

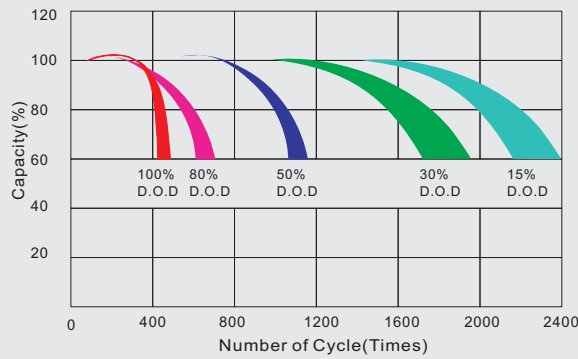

Storage characteristic

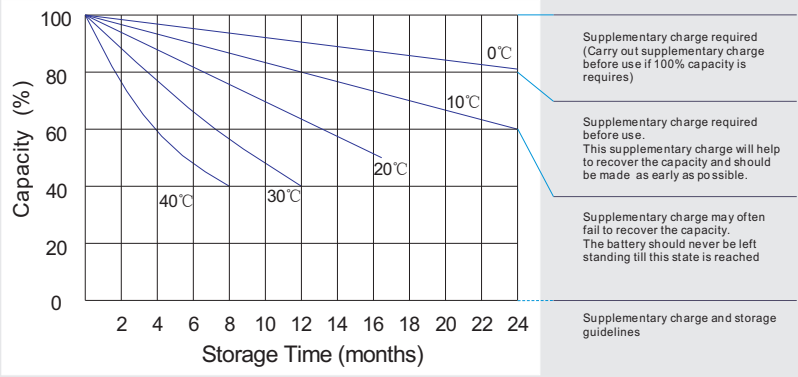

Charge characteristic curve for cyclic use

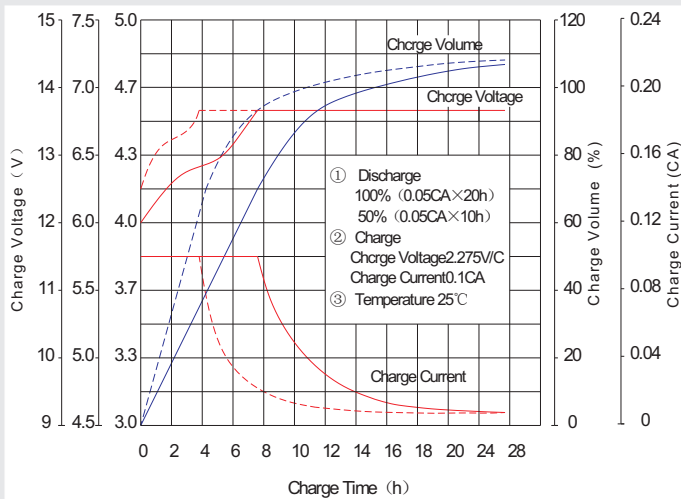

Discharge characteristic curve

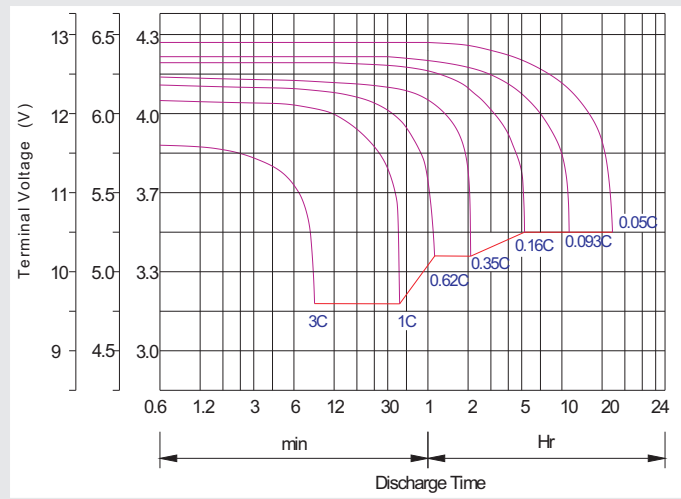

Capacity Factors With Different Temperature

Battery Type		-20°C	-10°C	0°C	5°C	10°C	20°C	25°C	30°C	40°C	45°C
GEL Battery	6V&12V	50%	70%	83%	85%	90%	98%	100%	102%	104%	105%
	2V	60%	75%	85%	88%	92%	99%	100%	103%	105%	106%
AGM Battery	6V&12V	46%	66%	76%	83%	90%	98%	100%	103%	107%	109%
	2V	55%	70%	80%	85%	92%	99%	100%	104%	108%	110%

Discharge Current VS. Discharge Voltage

Final Discharge Voltage V/cell	1.75V	1.70V	1.60V
Discharge Current (A)	(A) ≤ 0.2C	0.2C < (A) < 1.0C	(A) ≥ 1.0C

Maintenance & Cautions

Cycle service

- ※ Avoid battery over discharge, especially battery series connection use.
- ※ Charged with recommend voltage, ensure battery can be full recharged.
- In general, recharge capacity should be 1.1-1.15 times discharge capacity.
- ※ Effect of temperature on cycle charge voltage: -4mV/°C/Cell.
- ※ There are a number of factors that will affect the length of cyclic service.
- The most significant are depth of discharge, ambient temperature, discharge rate, and the manner in which the battery is recharged.
- Generally speaking, the most important factors is depth of discharge.

Charge the batteries at least once every six months, if they are stored at 25°C.

Charging Method:

Constant Voltage	-0.2Cx2h+2.4~2.45V/Cellx24h, Max. Current 0.3C
Constant Current	-0.2Cx2h+0.1Cx12h
Fast	-0.2Cx2h+0.2Cx6h