



steca
www.steca.com



**„Steca PV Off Grid – Power from the sun
for rural electrification.“**



PV Off Grid



Solar Home Systems

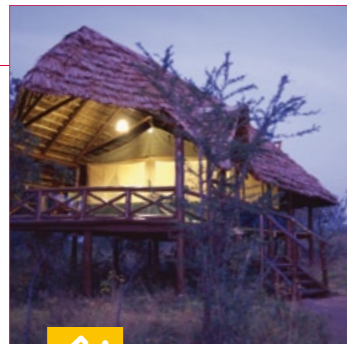

Inverter Systems



Hybrid Systems



Company

Content

	PV Off Grid – power from the sun ...	4
	Solar home systems	6
	Overview of devices	7
	Night light systems	8
	Overview of devices	9
	Steca's charging technology	10
	Inverter systems	12
	Overview of devices	13
	Hybrid systems	14
	Single-phase hybrid systems	16
	Three-phase hybrid systems	17
	Steca Solsafe	18
	Overview of devices	19
	Selecting an inverter and general recommendations	20
	Solar charge controllers	
	Steca PR	22
	Steca Solsum F	23
	Steca PR Night	24
	Steca PR	25
	Steca PR 2020 IP	26
	Steca Solarix PRS	27
	Steca Solarix MPPT	28
	Steca Solarix	29
	Steca Tarom	30
	Steca Power Tarom	31
	Steca PL 2085	32
	Sine wave inverters	
	Steca Solarix PI	33
	Steca Solarix PI with Steca Tarom	35
	Steca AJ	36
	Steca XPC	37
	Steca Compact	38
	Steca HPC	39
	Steca Xtender XTM	40
	Steca Xtender XTH	42
	Voltage converters	
	Steca MDC / MDCI	44
	Steca Solsum VC	45
	Solar refrigerator / freezer	
	Steca PF 166	46
	Energy-saving lights	
	Steca Solsum ESL	47
	Steca ULED11	48
	Fuel cells	
	Steca fuel cell and tank cartridge	49
	Accessories	
	Steca PA Tarcom	50
	Steca PA HS200	51
	Steca PA 15	52
	Steca PA EV200 DC	53
	Steca PA RC100	54
	Steca PA IRS 1008/180	54
	Steca RCC-02	55
	Steca PAx4	55
	Environmental protection in series	56
	Steca product ranges	58
	Room for notes	61
	Symbols	63





„**C**apture the sun's energy using intelligent systems from Steca: Growth based on reliability, - in use all over the world.“





Power from the sun ...

... for rural electrification.

Two billion people in rural areas still have no access to an electricity grid. Steca has set itself the target of improving the quality of life of these people. To this end, Steca develops and manufactures top-quality products which, thanks to their long lifetime, ensure extremely low costs.

Today, modern and professional electricity supplies are necessary in every part of the world. For these supplies, the focus is on high industrial demands, flexibility, environmental sustainability and reliability. Steca system technology for hybrid and telecommunication systems unites these aspects, thereby creating a basis for the forthcoming multimedia and communication age.

Solar home systems 

Inverter systems 

Single-phase and three-phase hybrid systems 

Steca solar charge controllers 

Steca sine wave inverters 

Accessories 



South Africa

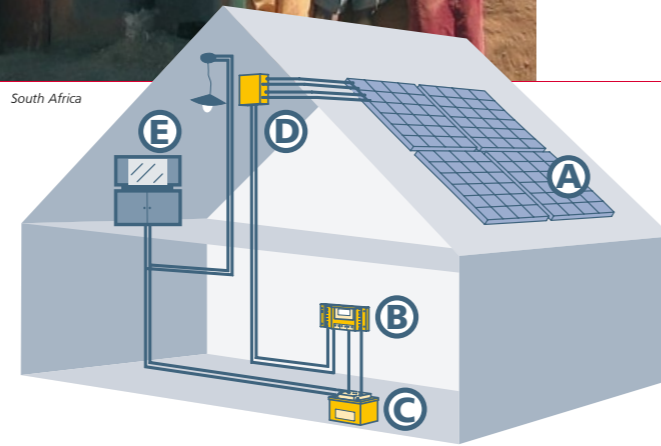

Key:

- A Solar modules
- B Solar charge controller
- C Battery
- D Generator junction box
- E Electrical load

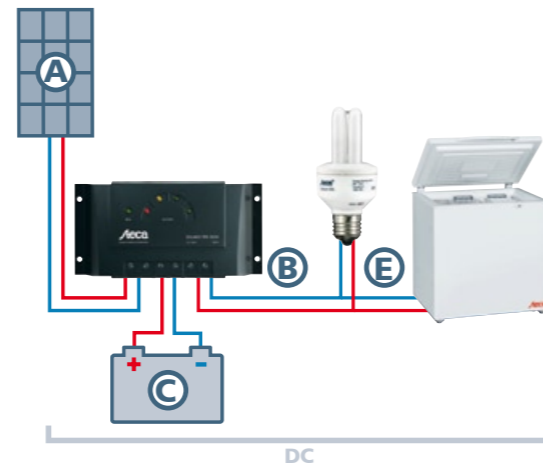

Solar home systems

with Steca solar charge controllers.

A solar home system consists of a Steca solar charge controller, one or more solar modules, a battery and the connected loads.

The Steca solar charge controllers control the energy flow of the entire system. They make sure that the solar module charges the battery quickly and effectively, but they also protect the battery against overcharging. If the loads discharge the battery, the solar charge controller, thanks to its precision in calculating the state of charge, switches off the load at exactly the right moment, thus protecting the battery from the dangers of deep discharge.

Furthermore, Steca solar charge controllers are equipped with an intelligent battery monitoring system. The most effective charging method is selected according to the requirements of the batteries. The solar charge controller is the central controlling component in solar home systems, for it affects all the functions of the system. For this reason, it is important to choose a reliable and high-performance solar charge controller.

Overview of devices:



Steca PR
Solar charge controller
3 - 5 A, 12 V
(page 22)



Steca Solsum VC
Voltage converter
1,5 A, 3 / 6 / 7,5 / 9 / 12 V
(page 44)



Steca Solsum ESL
Energy-saving light
5 W, 7 W, 11 W / 12 V
(page 47)



Steca ULED 11
Energy-saving light
1.1 W / 12 V
(page 48)



Steca Solsum F
Solar charge controller
5 - 10 A, 12 / 24 V
(page 23)



Steca PR
Solar charge controller
10 - 30 A, 12 / 24 V
(page 25)



Steca PL 2085
Solar charging point
8 x 5 A, 12 V
(page 32)



Steca PF 166
Solar refrigerator/freezer
12 / 24 V
(page 46)



Steca Solarix PRS
Solar charge controller
10 - 30 A, 12 / 24 V
(page 27)



Steca Solarix MPPT
Maximum Power Point Tracker
20 A, 12 / 24 V
(page 28)

The solar charge controller is connected directly to the battery using a cable as short as possible, and fixed to the wall near to the battery, so that it can be effectively cooled by the passing air flow.

In principle, the battery is always connected to the solar charge controller first. Then the solar module array is connected to the solar module input of the solar charge controller. Only direct current loads are used in solar home systems. They are connected directly to the load output of the solar charge controller.

This means the Steca solar charge controllers always show the battery's exact state of charge, and thus ensure optimal battery maintenance in all situations. Various Steca energy-saving lights, Steca solar cooling units, DC-to-DC converters and other loads can be used.



Sri Lanka



Australia





Greece

Overview of devices:

 <p>Steca PR Night Solar charge controller 6 - 10 A, 12 / 24 V (page 24)</p>	 <p>Steca PR Solar charge controller 10 - 30 A, 12 / 24 V (page 25)</p>	 <p>Steca PR 2020 IP Solar charge controller 20 A, 12 / 24 V (page 26)</p>	 <p>Steca Solsum F Solar charge controller 5 - 10 A, 12 / 24 V (page 23)</p>		
 <p>Steca Solarix PRS Solar charge controller 10 - 30 A, 12 / 24 V (page 27)</p>	 <p>Steca Solarix MPPT Maximum Power Point Tracker 20 A, 12 / 24 V (page 28)</p>	 <p>Steca Tarom Solar charge controller 30 - 45 A, 12 / 24 / 48 V (page 30)</p>	 <p>Steca Power Tarom Solar charge controller 55 - 140 A, 12 / 24 / 48 V (page 31)</p>		
 <p>Steca PA 15 Remote control 720 W (page 52)</p>	 <p>Steca PA EV200 DC DC relay 12 / 24 / 48 V (page 53)</p>	 <p>Steca PA IRS 1008/180 Motion detector (page 54)</p>	 <p>Steca Solsum ESL Energy saving lamp 5 W, 7 W, 11 W / 12 V (page 47)</p>	 <p>Steca ULED 11 Energy-saving light 1.1 W / 12 V (page 48)</p>	 <p>Steca street lamp with energy-saving lamp Steca ESL 11 W</p>

Night light systems

... are an important special application of solar home systems.

These fit with the design of the solar home systems, but are equipped with a special Steca solar charge controller which automatically turns on the connected lights for a set time after sunset, and turns them off again the next morning at the latest. These systems are perfectly suited for street lamps and automatic night-time lighting.

Another special model makes these systems to the ideal solution for bus stops and similar applications. Operating in conjunction with a motion detector, the lamp is only turned on at night time when movement is detected in a specified area. After a few minutes, the light is then automatically turned off again. This function can be implemented with any Steca night light charge controller by connecting it to an external motion detector.



Spain



Duration of night light function "Light on":	All night	After sunset	Before sunrise	Turn-on time delay	Maximum light current	Catalogue page
Solar charge controller:						
Steca Solsum F	■*	0 - 12 h	-	-	10 A	23
Steca PR Night	■	0 - 6 h	0 - 6 h	-	10 A	24
Steca PR	■	0 - 8 h	-	-	30 A	25
Steca PR 2020 IP	■	0 - 8 h	-	-	30 A	26
Steca Solarix PRS	■*	0 - 12 h*	-	-	30 A	27
Steca Solarix MPPT 2010	■*	0 - 12 h	-	-	20 A	28
Steca Tarom Steca Power Tarom Steca PA 15 / Steca PA 15 with PA EV200 DC relay	■	0 - 12 h	-	0 - 3 h	15 A 200 A	30 31 52 53

* only for projects with larger order quantities.
The type of night light function selected must be specified in the order.

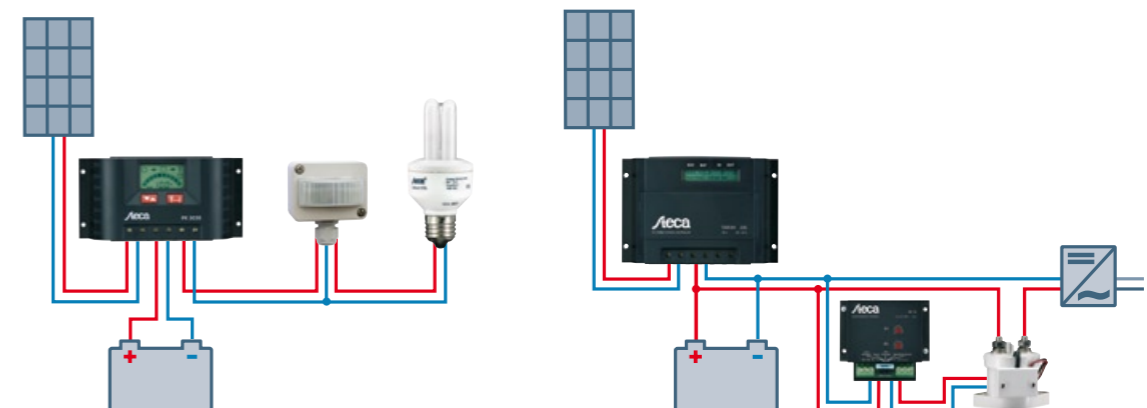

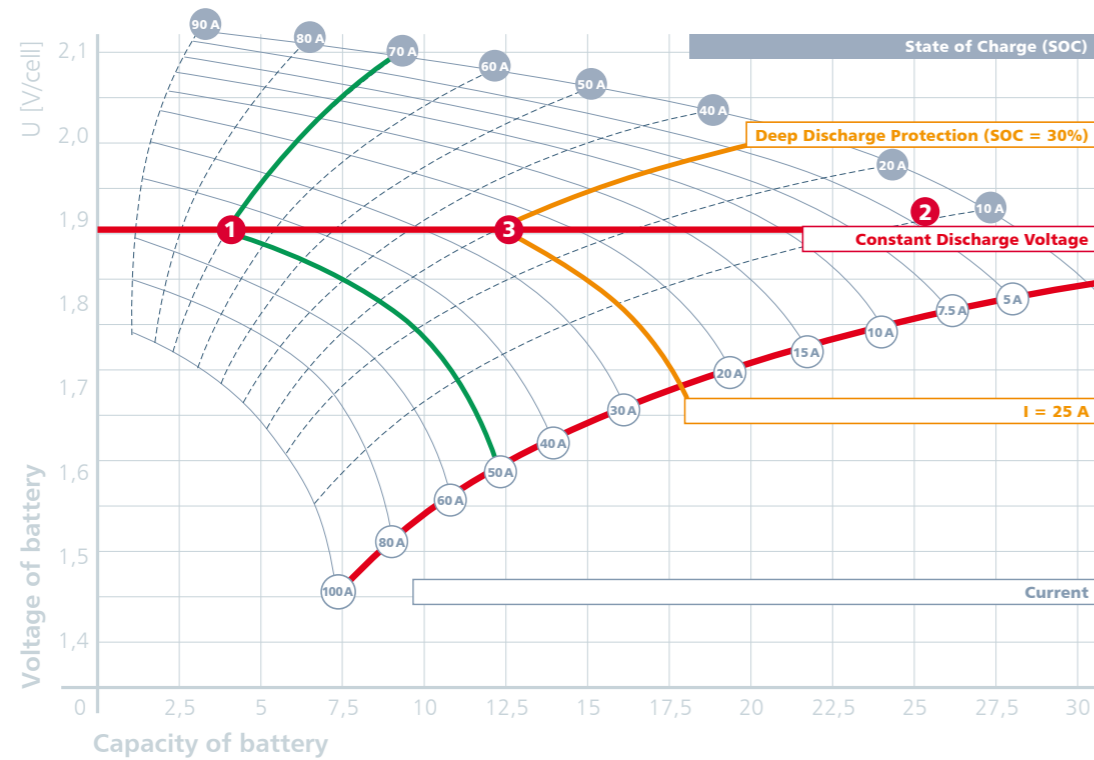

Figure on the left-hand side

... shows the characteristics of a lead-acid battery with a rated capacity of 28 Ah. Its voltage changes in relation to the charge and discharge currents and the state of charge. If a fixed discharge cut-off voltage of 11.1 V is now specified, this means that, at a discharge current of 50 A, a full battery is disconnected when its state of charge is still 70% (**point 1**). This is represented in the diagram by the green line. The majority of the capacity which is still available cannot be used in this case.

If the same battery is discharged with 5 A, however, the system disconnects it at the same fixed voltage of 11.1 V, which in this case means at a state of charge of around 10% (**point 2**).

This is already a dangerously low state of charge which can result in significant damage to the battery. Only with a discharge current of 25 A would the battery in this case be correctly disconnected at an SOC of 30% (**point 3**).

Using the Steca state of charge algorithm the charger is able to disconnect the battery at the correct threshold with any discharge current. The cut-off voltage is determined by the point at which the 30% line crosses the discharge current line (Steca SOC deep-discharge protection). Only a method of this kind can ensure that the battery is maintained correctly, and thus has a long service life.

Which chargers from Steca carry the optimised algorithm?

The Steca product range is divided into two lines. One is optimised for use in simple applications with less demand and equipped with the minimum necessary features. The other line is designed to cover high-end demand to supply a good communication interface to the user and optimised battery maintenance features. For both lines there exist solar charge controllers in a wide power range. All chargers equipped with the special Steca State of Charge algorithm are marked with the SOC symbol in this catalogue (see overview page 63).

Steca's charging technology

The Steca products stand out thanks to an optimal state of charge determination. This is the key to the batteries having a long service life.

What does SOC mean?

SOC means the current 'state of charge' of the battery. This is given as a percentage. A battery is fully charged when the SOC is at 100%. The lowest value which can be reached is 0%. In theory, all other values in between can be reached, but most types of batteries should not reach state of charge values of less than 30%. Such values can quickly lead to dangerous deep discharges which decrease the service life of the batteries or destroy them directly. A battery's state of charge should not be confused with its remaining available capacity. The actual remaining capacity depends on many parameters such as the temperature, age and history of the battery and many others. It is possible to gain a rough estimate of a battery's current remaining capacity by multiplying the correct state of charge of the battery by its rated capacity. As the age of the battery increases, however, the rated capacity can change significantly, which means that the prediction of the available capacity can be strongly distorted.

Why is a state of charge determination so important?

During charging, the solar charge controller has to know when the battery is fully charged so that it can protect it against overcharging at the right moment and in the correct manner. When discharging the battery it is equally important to know the state of charge in order to protect the battery against harmful deep discharge. In order to carry out this function, there are various criteria which can indicate how full the battery is at a given time. Some of these criteria are better suited than others. The simplest and most common criterion is the voltage of the battery. With this method, a fixed charge cut-off voltage is defined. When this voltage is reached, charging is stopped. A fixed deep discharge threshold is also defined. If the battery voltage falls below this value, the load is switched off. This method is simple, since the voltage of the battery is easy to measure precisely, yet it is not ideal for most types of batteries because their state of charge does not change in direct proportion to the voltage. Low discharge currents are common in solar power systems in particular. This leads to inadequate battery maintenance if fixed voltage values determine the charging or discharging processes. The full-charge and deep-discharge thresholds provide better so-

lutions, for the battery currents are taken into account alongside the voltage. But this method does not allow the state of charge to be determined accurately either, since many important factors are not considered. Only if the state of charge is calculated precisely is it possible for the solar charge controller to treat the battery correctly, to end a charge cycle using the solar module at the correct time and to switch off a load neither too early nor too late. For this reason, Steca has developed a high-performance algorithm with which the state of charge can be calculated with a sufficient degree of accuracy and the battery can be optimally protected.

How does Steca's state of charge determination work?

Steca's algorithm for determining a battery's state of charge is a combination of various methods which ensure that the SOC is calculated accurately enough and delivers reliable, stable values over a long period of time. Furthermore, attention is paid to making a calculation method which can be carried out simply and at a low cost in various solar charge controllers. Years of experience in the research and development

of battery state of charge algorithms has led to an auto-adaptive 'fuzzy logic' algorithm. This includes the age and usage history of the battery in the calculation as well as the other important parameters. The battery voltage and its currents and the temperature are constantly measured as accurately as possible by the solar charge controller. During a learning phase, the solar charge controller estimates the state of charge on the basis of experience values. At the same time, the controller monitors the behaviour of the battery and adjusts various parameters to the current system. The learning phase lasts for a few cycles. The advantage of this method is that it makes it possible to respond dynamically to the requirements of the system and individually adjust the battery maintenance to the requirements of every individual system. This feature explains the high performance and reliability of the Steca battery state of charge algorithm. At the same time, this algorithm guarantees optimum battery maintenance, which is reflected in the long service life of the battery. In addition, the user benefits from the fact that the battery's current state of charge can be displayed, which means the user constantly has optimal control over the system.



Overview of devices:



Steca PR
Solar charge controller
10 - 30 A, 12 / 24 V
(page 25)



Steca Solarix PRS
Solar charge controller
10 - 30 A, 12 / 24 V
(page 27)



Steca Solarix PI
Sine wave inverter
550 - 1,100 W, 12 / 24 V
(page 33)



Steca Solarix
Solar charge controller
40 A, 12 / 24 / 48 V
(page 29)



Steca Solarix MPPT
Maximum Power Point Tracker
20 A, 12 / 24 V
(page 28)



Steca Tarom
Solar charge controller
30 - 45 A, 12 / 24 / 48 V
(page 30)



Steca AJ
Sine wave inverter
500 - 2,400 W, 12 / 24 / 48 V
(page 36)

DC

AC

Inverter systems

for both AC and DC.

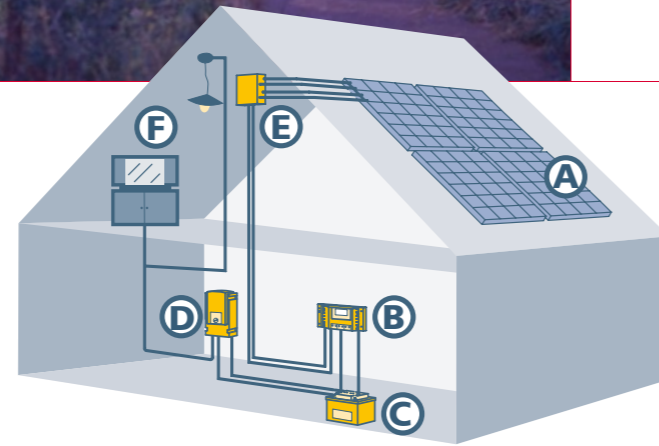

- Key:**
- A Solar modules
 - B Solar charge controller
 - C Battery
 - D Sine wave inverter
 - E Generator junction box
 - F Electrical load
(12 V ... 48 V DC, 115 V ... 230 V AC)

Inverter systems are designed as solar home systems. The central solar charge controller ensures the battery is charged correctly and protects it against overcharging. In addition, a stand-alone inverter is connected directly to the battery in these systems so that AC appliances can be operated.

If DC appliances are also used, they can be connected directly to the charge controller.

An AC system can be created with a system voltage or battery voltage of 12 V, and also with 24 V or 48 V for greater capacities.

The simple system concept makes installation quick and easy.

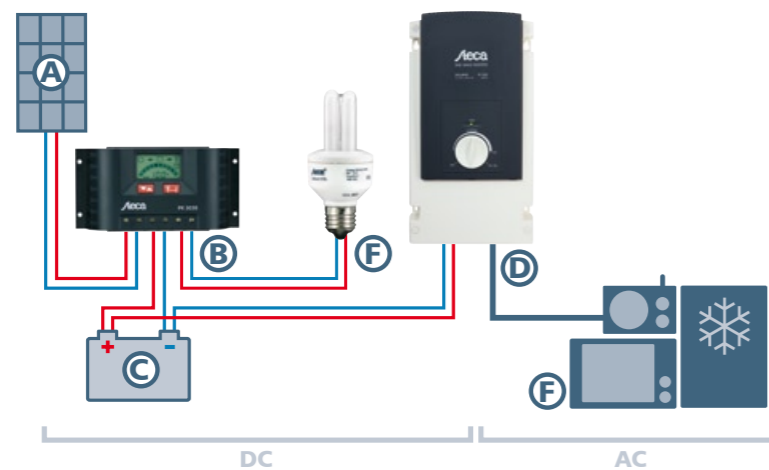

Greece



South Africa





Austria

Overview of devices:



Steca Tarom
Solar charge controller
30 - 45 A, 12 / 24 / 48 V
(page 30)



Steca PA 15
Solar charge controller
10 - 30 A, 12 / 24 V
(page 52)



Steca XPC
Sine wave inverter
1,400 W - 2,200 W
(page 37)



Steca Compact
Sine wave inverter
1,600 W - 4,000 W
(page 38)



Steca HPC
Sine wave inverter
2,800 W - 8,000 W
(page 39)



Steca Power Tarom
Solar charge controller
55 - 140 A, 12 / 24 / 48 V
(page 31)



Steca PA HS200
Shunt
10 - 65 V
(page 51)



Steca PA Tarcom
Data logger
12 / 24 / 48 V
(page 50)



Steca Xtender XTM
Sine wave inverter
1,500 W - 36,000 W
(page 40)



Steca Xtender XTH
Sine wave inverter
3,000 W - 72,000 W
(page 42)

DC

AC

Hybrid systems

The main feature of a hybrid system is the use of two or more different electricity sources.

Alongside solar energy, photovoltaic hybrid systems generally employ a diesel generator, a wind turbine or the public grid as a further electricity source. The inverters used in hybrid systems, which have integrated battery chargers, supply the connected AC loads according to demand from the battery bank of solar energy or the second electricity source. These devices also allow the batteries to be recharged from the extra energy source.



Rwanda

Photovoltaic hybrid systems offer the advantage that the solar generator does not have to be significantly oversized for periods of low sunlight. This avoids substantial costs. When selecting its energy source, the system always gives priority to the energy provided by the module. In combination with a controllable second source, the energy supply remains reliable and available 24 hours a day, all year round.



United Kingdom

Important features for single-phase and three-phase hybrid systems

- Combination of different power sources such as PV, wind, diesel generators
- 400 V AC three-phase and 230 V AC single-phase available 24 hours a day
- 12 V / 24 V or 48 V overall DC bus
- Automatic energy management based on the state of charge calculation of the battery, including automatic start of controllable power sources like e. g. diesel generators
- Optimised battery charging algorithm
- Data logger function with automatic alarm and remote monitoring (GSM)
- Optimised system efficiency through DC and AC bus



Africa



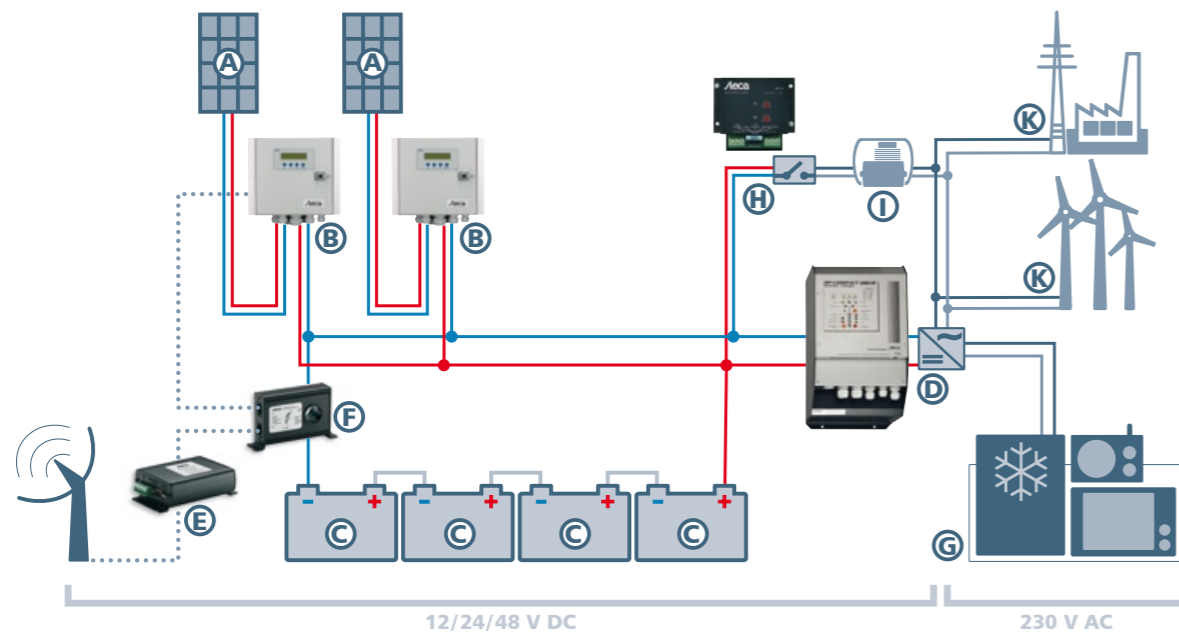

Key:

- A Solar modules
- B Solar charge controller Steca Power Tarom
- C Battery
- D Sine wave inverter Steca HPC
- E Data logger Steca PA Tarcom
- F Current sensor (Shunt) Steca PA HS200
- G Electrical load (230 V AC)
- H Remote control Steca PA 15
- I Diesel generator
- K Public grid/Wind energy

Single-phase hybrid systems

The central, intelligent element within the system is the Steca Tarom or Power Tarom solar charge controller: it controls the energy flow and protects the battery against critical states. Steca Tarom/Power Tarom is directly connected to the battery, just as the DC bus is. Using a shunt, the Steca PA HS200, which is situated on the minus cable attached to the battery, the battery current is measured and this information is passed on to the Steca Tarom / Power Tarom. Further components, such as an inverter or the Steca PA 15 remote control, are directly connected to the DC bus. In order to automatically start a diesel generator if the battery's state of charge (SOC) falls below an adjustable threshold, the output of the Steca PA 15 is connected to a relay. The normally open contact of the relay switches the diesel generator on, and subsequently switches it off again.

The Steca Tarom / Power Tarom controls the DC hybrid system. The Steca PA HS200 current sensor transfers all information on the charge and discharge currents at the DC bus to the Steca Tarom / Power Tarom. With the aid of this data, the controller is able to calculate the current state of charge of the battery. This information is transferred via the DC cabling (powerline modulation) to all connected Steca PA 15. Every Steca PA 15 can be independently configured to a certain switch-on and switch-off threshold of the state of charge.

If, in the above example, the inverter is discharging the battery, then this information is transferred to the Steca Tarom / Power Tarom, which calculates the state of charge. As soon as the state of charge falls below the appointed threshold value of the connected Steca PA 15 (e.g. 30 %), the controller switches on the diesel generator via a relay. The load

is now being supplied from the generator, and at the same time the battery is being recharged. After the state of charge has reached the Steca PA 15's appointed upper value (e.g. 90 %), the diesel generator is switched off again.

In order to create an automatic energy management system, the AC output of the diesel generator is connected to the AC input of the inverter (with integrated battery charger). The load is always connected to the output of the inverter. If the diesel generator is running, and this current flows to the inverter, then the inverter automatically switches to transfer mode. The loads are supplied from the diesel generator whilst the battery recharges via the inverter. If the AC output voltage of the diesel generator falls under a certain voltage level, which can be adjusted on the inverter, then battery operation is automatically switched back on.

This system allows for automatic energy management which gets optimum use from the available solar energy, maintains the batteries reliably, and ensures electricity supply around the clock.

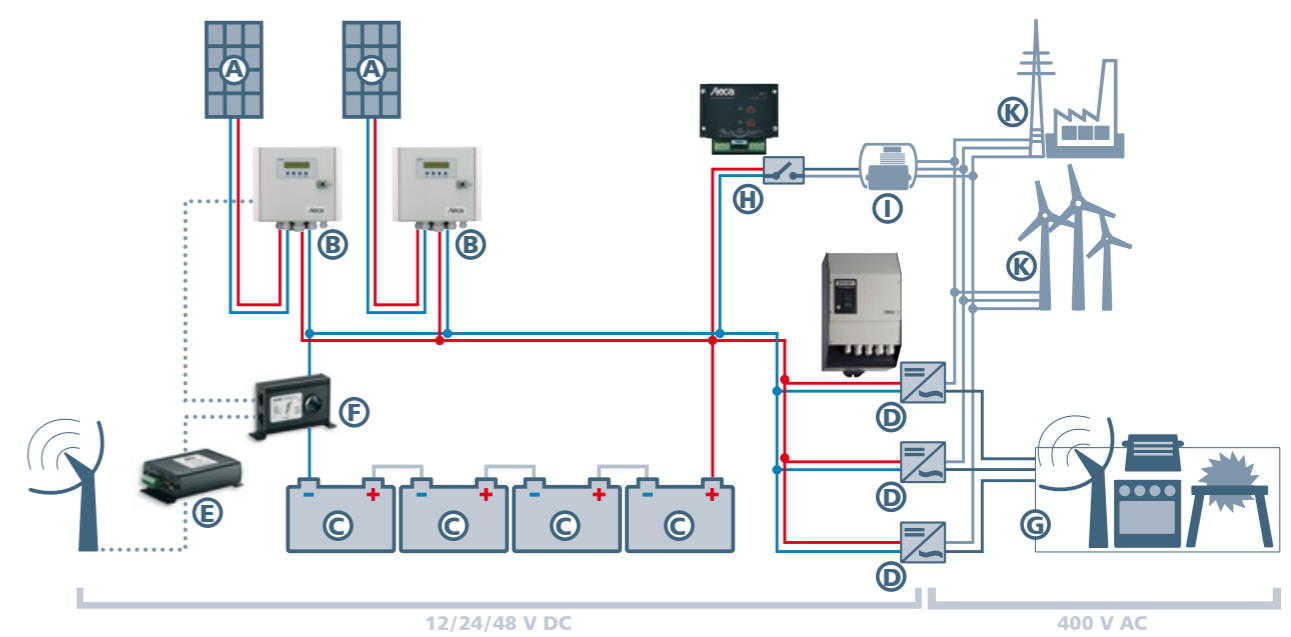

Key:

- A Solar modules
- B Solar charge controller Steca Power Tarom
- C Battery
- D 3 sine wave inverter Steca Xtender XTH
- E Data logger Steca PA Tarcom
- F Current sensor (Shunt) Steca PA HS200
- G Electrical load (400 V AC)
- H Remote control Steca PA 15
- I Diesel generator
- K Public grid/Wind energy

Three-phase hybrid systems

The control concept is similar to that of the single-phase system. If more than one Steca Tarom / Power Tarom is employed, one of the devices must be designated as the master Tarom. All other charge controllers are then automatically designated as slave Taroms. The master Tarom / Power Tarom is directly connected to the battery and all slaves are connected to the DC bus. Only the master Tarom / Power Tarom shows the correct state of charge on its display and controls the energy flow around the system. Slave Taroms / Power Taroms perform the function of controlling the charging from the connected PV modules.

In order to assemble a three-phase energy supply, three inverters are connected to the DC bus. For this, the inverters must be specially designed in order to allow three-phase operation. Various three-phase generators can be connected to the three inverters for controlled recharging of the battery via a Steca PA 15 and a relay. These may be wind, water, or diesel generators; or the public grid. Suitable inverters with integrated battery chargers in three-phase mode are the Steca Xtender devices, which can be employed from 12 V / 2 kW to 48 V / 24 kW per phase. In total, a maximum of 72 kW can be supplied.

Both single-phase and three-phase hybrid system concepts are based on the same principles of energy management. With the help of the Steca PA HS200 current sensor, the charge and discharge currents of the components, such as slave Taroms/Power Taroms, inverters etc., are determined and communicated to the master Tarom / Power Tarom. Based on the calculated state of charge of the battery, the Steca PA 15 switches the extra generator on or off. The three single-phase inverters switch off if the voltage falls below a given threshold in order to protect the battery from deep discharge.



Australia

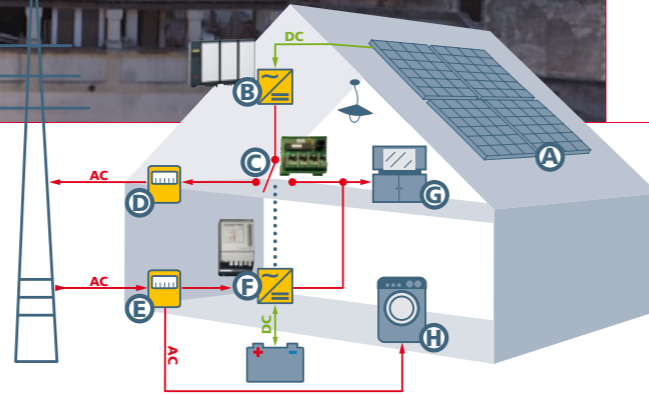
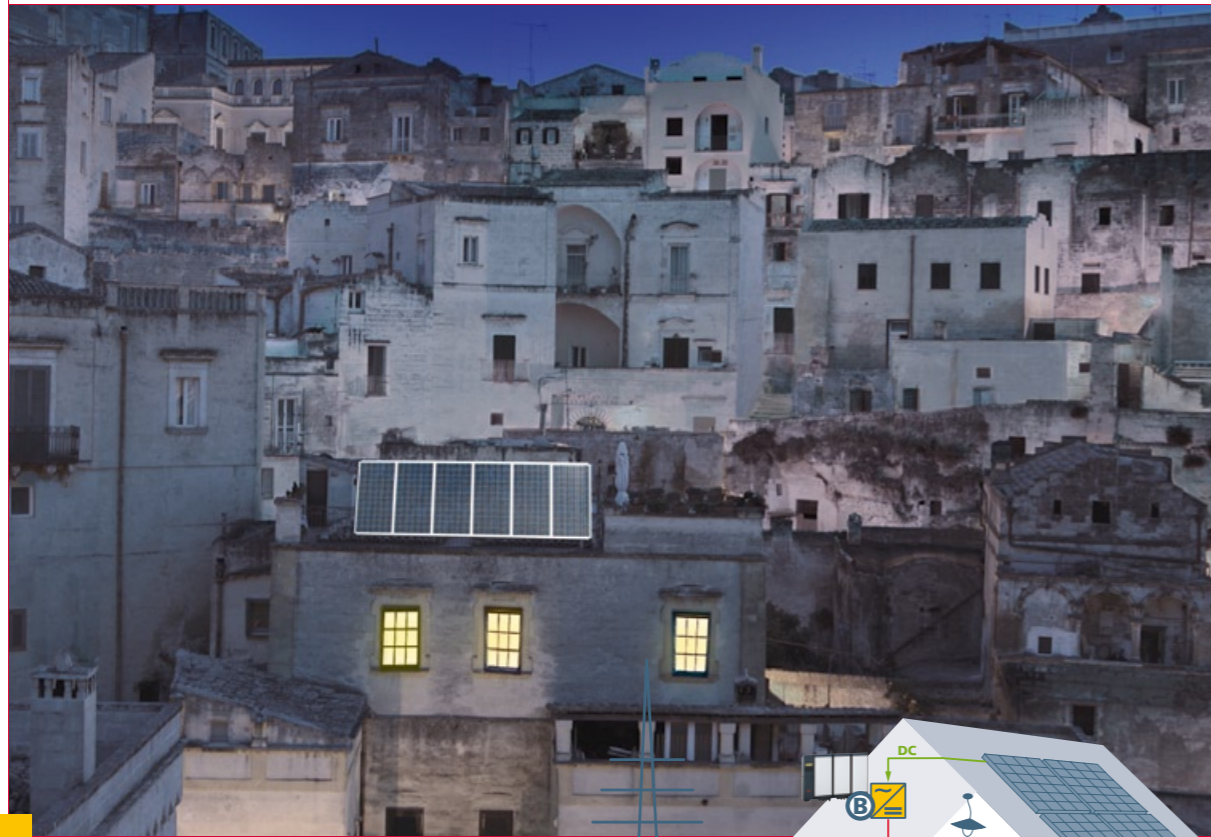

Steca Solsafe

Blackout - and yet it stays light!

Large-scale power supply failures are becoming increasingly common. With emergency systems such as generators or uninterruptible power supplies (UPS), the power supply can be assured.

Yet, in the event of a power outage, the grid-connected PV system also stops working. This means that although power may be available, it cannot be used. The Solsafe system offers a simple, efficient and cost-effective solution to this problem.

Installing one of our combined inverters Steca XPC, Steca Compact, Steca HPC, Steca Xtender XTM or Steca Xtender XTH with the supplementary ARM-01 relay module and a battery system turns any grid-connected PV system into an emergency power supply in the event of a power outage. If the public grid is available, the electrical output generated by the solar modules is fed directly into the grid by the grid inverter (B) and the grid-feed electricity meter (D). In parallel to this, the unsupplied loads (H) receive power directly from the grid, via the consumption electricity meter (E). The batteries are kept fully charged from the public grid via the hybrid system inverter (F), and, if necessary, they are recharged. Furthermore, the supplied loads (G) receive power from the public grid during transfer mode.

Key:

- A Solar modules
- B Grid inverter
- C Relay module ARM-01
- D Grid-feed electricity meter
- E Consumption electricity meter
- F Sine wave inverter
- G Supplied loads
- H Unsupplied loads

If there is a grid outage, the hybrid system inverter automatically switches mode to operate as a sine wave inverter, and continues to feed power to the supplied loads (G) without any interruption. Because the grid inverter can no longer supply power to the grid, its output is channelled directly to the supplied loads (G) by the ARM-01 relay module (C). In this way, the loads can receive power directly from the grid inverter of the solar modules. At the same time, the battery can be recharged with the available solar energy, which increases the length of time for which the supplied loads can receive power during the night.

With this set-up, the capacity of the battery can be kept small, allowing for an optimal design of system costs.

The Solsafe system is fully automatic, and can be integrated into any new or existing PV system.

Solsafe ensures the power supply, and furthermore allows the solar energy to be fully utilised.

Overview of devices:

 Steca XPC Sine wave inverter 1,400 W - 2,200 W <i>(page 37)</i>	 Steca Compact Sine wave inverter 1,600 W - 4,000 W <i>(page 38)</i>	 Steca HPC Sine wave inverter 2,800 W - 8,000 W <i>(page 39)</i>	 ARM-01 Relay module for Steca sine wave inverter	 Solasafe S-Box Anti-blackout system for Steca sine wave inverter
 Steca Xtender XTM Sine wave inverter 1,500 W - 36,000 W <i>(page 40)</i>	 Steca Xtender XTH Sine wave inverter 3,000 W - 72,000 W <i>(page 42)</i>	 StecaGrid 300 and StecaGrid 500 Grid inverter 300 W - 3,600 W <i>(Steca PV Grid Connected)</i>	 StecaGrid 2010+ Grid inverter 2,000 W up to several 10,000 W StecaGrid 2000+, StecaGrid 1900 <i>(not shown)</i> <i>(Steca PV Grid Connected)</i>	 StecaGrid 10000 3ph Grid inverter 10,000 W up to several 100,000 W StecaGrid 9000 3ph <i>(not shown)</i> <i>(Steca PV Grid Connected)</i>

Why choose Steca Solsafe?

- It allows great system flexibility. The grid inverter is designed according to the PV generator, and the sine wave inverter according to the desired emergency power supply.
- The PV system's output and operating voltage can be freely selected, and do not depend on the size and battery voltage of the emergency power supply.
- It should be noted, however, that the AC output of the grid inverter may never be greater than the rated output of the sine wave inverter.
- The PV voltage of the grid inverter does not depend on the battery voltage.
- Existing grid-connected solar power systems can be fitted with Steca Solsafe without alterations of any kind.
- The available PV capacity is added to that of the sine wave inverter in the event of a power outage, or the solar power is stored in the battery.



General recommendations for alternating current and hybrid systems.

Selecting an inverter

The power of the inverter must be selected according to the way it will be used. The sum of the power of all loads must not exceed the rated power of the inverter. The maximum power of the inverter must be able to cover the starting currents of the loads. In order to allow the connection of more loads, Steca recommends overdimensioning the inverter.

Sine wave inverters

In contrast to so-called square wave or trapezoidal inverters (grey square curve), Steca sine wave inverters produce a real and precisely controlled sinus wave (red sinus wave) at their output. The sinus wave inverters assure that all loads which are suitable for grid operation can also be operated on a solar home system without any problems. Furthermore, they offer the advantage that no significant noises are produced in the inverter and there is no loud background noise to be heard on a connected radio, for example.

a high overload capacity, particularly in the start-up phase. The battery must also possess a large enough capacity so that sufficient currents are made available to the inverter in the start-up phase. We recommend choosing the battery size according to the following formula: the battery capacity should be at least five times as large as the rated power of the inverter divided by the rated voltage of the battery.

$$C_{\text{batt}} \geq 5 \text{ h} * P_{\text{nom}} / U_{\text{nom}}$$

P_{nom} is the rated power of the inverter in watts and U_{nom} is the rated voltage of the battery.

P_{nom} inverter	U_{nom} battery	Battery capacity
200 W	12 V	> 100 Ah
500 W	12 V	> 200 Ah
1,000 W	12 V	> 400 Ah
2,000 W	12 V	> 800 Ah
2,000 W	24 V	> 400 Ah
3,500 W	24 V	> 700 Ah
3,500 W	48 V	> 350 Ah
5,000 W	48 V	> 500 Ah
7,000 W	48 V	> 700 Ah

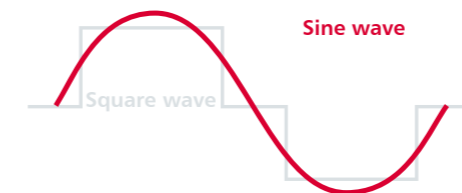

Selecting the system voltage

The power requirement of the loads should be the decisive factor when choosing the system voltage. The higher the power, the higher the system voltage. If no 12 V DC loads are connected to the system, a higher system voltage of 24 V or 48 V should be chosen in order to reduce the alternating currents, and thus the losses on the DC side. Inverters also generally work more effectively with a higher input voltage. All in all, a higher system voltage leads to the system having a greater efficiency, since losses are reduced.

Cable lengths and cross sections

Direct currents in inverter systems are typically large. For this reason, it is important to dimension the cables between the battery and the inverter appropriately. Always connect the inverter directly to the battery. The cable you use should be as short as possible. In addition, the cable cross section should match the expected flow of current. In case of doubt, a thicker cable should be chosen. This can have a significant influence on the overall behaviour of the system. Using thick and short cables can limit losses and thus allow you to create a system with a better level of efficiency and/or better performance.

If the cables on the direct current side of the inverter are included in the delivery, these should not be lengthened, and a smaller cross section should not be used.

Selecting the PV generator and solar charge controller

The solar module array has to be adjusted to the local sunlight conditions and the system's energy requirement. In order to avoid stagnation times, the PV generator must also provide enough power during months with little solar radiation in order to cover the requirement of the connected loads.

The chosen solar charge controller must also be suitable for the maximum short-circuit current of the PV generator and the maximum load current. In some applications, however, technical properties also play an important role in the choice of solar charge controller. This may mean that a high-performance solar charge controller with corresponding additional functions is used in a system with a low output.

In order to keep the initial investment small, we recommend planning the size of the PV generator and battery according to the current energy consumption and choosing a solar charge controller which will allow the system to be expanded later.

Selecting the battery

In order to also be able to supply loads with high requirements without any problems, the size of the battery must be chosen with care. Some critical loads such as fridges, freezers, pumps and motors need extremely high starting currents in their start-up phases. In order to be able to power such loads, it is important to use a high-performance inverter with

Inverter selection

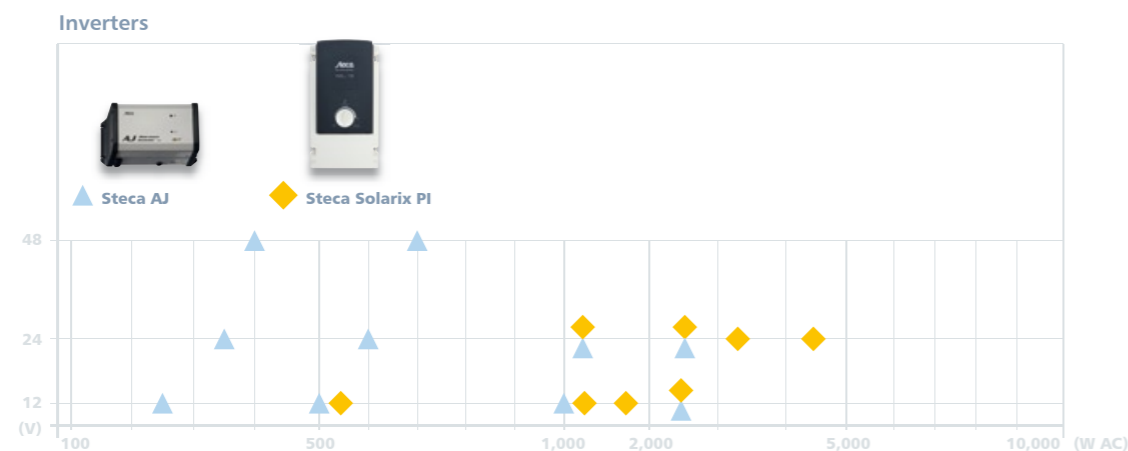

Steca PR

PR 0303, PR 0505

The Steca PR 0303 and PR 0505 solar charge controllers are optimally suited for use in small solar home systems with module currents up to 5 A.

A 75 Wp module can be connected, which easily allows operation of lamps, radios and a small television. All loads can be switched off using the manual load switch on the controller. The extremely low own consumption makes the Steca PR especially suitable for professional applications in telecommunications and traffic management technology. Since this is a serial controller, it is extremely flexible in the type of power source that can be connected. The electronic fuse makes the controller completely maintenance-free and robust.

Product features

- Series controller
- Voltage regulation
- PWM control
- Multistage charging technology
- Current compensated load disconnection
- Automatic load reconnection
- Temperature compensation
- Common positive grounding or negative grounding on one terminal

Electronic protection functions

- Overcharge protection
- Deep discharge protection
- Reverse polarity protection of load, module and battery
- Automatic electronic fuse
- Short circuit protection of load and module
- Overvoltage protection at module input
- Open circuit protection without battery
- Reverse current protection at night
- Overtemperature and overload protection
- Battery overvoltage shutdown

Displays

- Multi-coloured LED
- 3 multi-coloured LEDs show operating states
- for operation, state of charge, fault messages

Operation

- Manual load switch

Certificates

- Approved by the World Bank for Laos
- Compliant with European Standards (CE)
- RoHS compliant
- Made in Germany
- Developed in Germany
- Manufactured according to ISO 9001 and ISO 14001

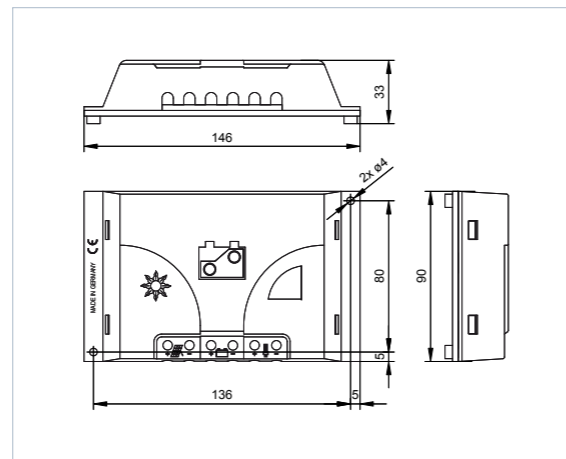
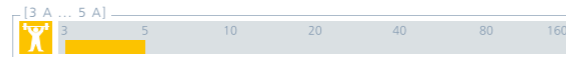

	PR 0303	PR 0505
Characterisation of the operating performance		
System voltage	12 V	
Own consumption	3 mA	
DC input side		
Open circuit voltage solar module	< 47 V	
Module current	3 A	5 A
DC output side		
Load current	3 A	5 A
End of charge voltage	13.7 V	
Boost charge voltage	14.4 V	
Reconnection voltage (LVR)	12.5 V	
Deep discharge protection (LVD)	11 V ... 11.5 V	
Operating conditions		
Ambient temperature	-25 °C ... +50 °C	
Fitting and construction		
Terminal (fine / single wire)	6 mm ² / 10 mm ² - AWG 10 / 8	
Degree of protection	IP 32	
Dimensions (X x Y x Z)	146 x 90 x 33 mm	
Weight	160 g	

Technical data at 25 °C / 77 °F

Steca Solsum F

6.6F, 8.8F, 10.10F

The Steca Solsum F-Line continues the huge success of one of the most used SHS controllers. With a power range of up to 10 A at automatically recognized 12 V or 24 V it fits to a system sizes of maximum 240 W.

The circuit board is completely electronically protected and with the LED user interface it is easy to check the battery state of charge at any time. Large terminals guarantee a simple connection of solar panels, battery and load. The Steca Solsum F works on PWM as a low loss series controller.

Product features

- Series controller
- Voltage regulation
- Automatic detection of voltage
- PWM control
- Multistage charging technology
- Current compensated load disconnection
- Automatic load reconnection
- Temperature compensation
- Common positive grounding or negative grounding on one terminal
- Monthly maintenance charge

Electronic protection functions

- Overcharge protection
- Deep discharge protection
- Reverse polarity protection of load, module and battery
- Automatic electronic fuse
- Short circuit protection of load and module
- Overvoltage protection at module input
- Open circuit protection without battery
- Reverse current protection at night
- Overtemperature and overload protection
- Battery overvoltage shutdown

Displays

- Multifunction LED display
- Multi-coloured LED
- 4 LEDs show operating states
- for operation, state of charge, fault messages

Options

- Night light function pre-set in the factory or adjustable via Steca PA RC 100
- Parameterisation of function values via Steca PA RC 100

Certificates

- Compliant with European Standards (CE)
- RoHS compliant
- Developed in Germany
- Manufactured according to ISO 9001 and ISO 14001

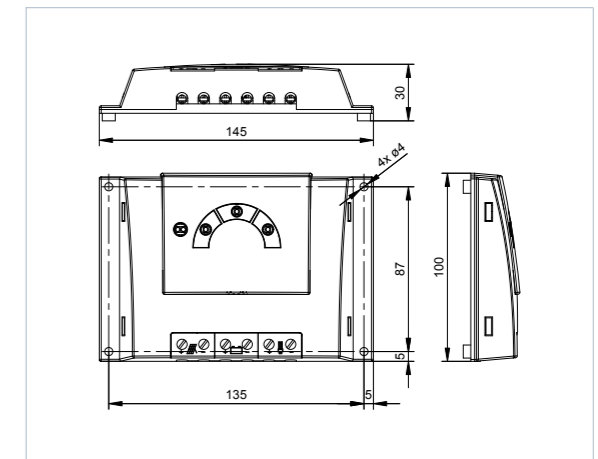
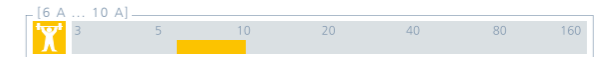

	6.6F	8.8F	10.10F
Characterisation of the operating performance			
System voltage	12 V (24 V)		
Own consumption	< 4 mA		
DC input side			
Open circuit voltage solar module	< 47 V		
Module current	6 A	8 A	10 A
DC output side			
Load current	6 A	8 A	10 A
End of charge voltage	13.9 V (27.8 V)		
Boost charge voltage	14.4 V (28.8 V)		
Reconnection voltage (SOC / LVR)	> 50 % / 12.4 V ... 12.7 V (24.8 V ... 25.4 V)		
Deep discharge protection (SOC / LVD)	< 30 % / 11.2 V ... 11.6 V (22.4 V ... 23.2 V)		
Operating conditions			
Ambient temperature	-25 °C ... +50 °C		
Fitting and construction			
Terminal (fine / single wire)	4 mm ² / 6 mm ² - AWG 12 / 9		
Degree of protection	IP 32		
Dimensions (X x Y x Z)	145 x 100 x 30 mm		
Weight	approx. 150 g		

Technical data at 25 °C / 77 °F



Remote control Steca PA RC100 (page 54)



Steca PR Night

PR 0606N, PR 1010N

The Steca PR Night is designed for operating automatic night light systems and is suitable for solar systems of up to 300 Wp module output.

This controller is thus especially suitable for streetlights, bus stops, advertising lighting and other similar applications. The charge controller determines the actual solar time via the solar module. This integrated clock can be used to define how long after sunset, or before sunrise, the light is to be switched on or off.

Product features

- Hybrid controller
- State of charge determination with Steca AtonIC (SOC)
- Automatic detection of voltage
- PWM control
- Multistage charging technology
- Load disconnection depending on SOC
- Automatic load reconnection
- Temperature compensation
- Common positive grounding or negative grounding on one terminal
- Night light function
- Integrated self test
- Monthly maintenance charge

Electronic protection functions

- Overcharge protection
- Deep discharge protection
- Reverse polarity protection of load, module and battery
- Automatic electronic fuse
- Short circuit protection of load and module
- Overvoltage protection at module input
- Open circuit protection without battery
- Reverse current protection at night
- Overtemperature and overload protection
- Battery overvoltage shutdown

Displays

- Multi-coloured LED
- 3 multi-coloured LEDs show operating states – for operation, state of charge, fault messages

Operation

- Programming by buttons
- Manual load switch

Certificates

- Approved by the World Bank for Laos
- Compliant with European Standards (CE)
- RoHS compliant
- Made in Germany
- Developed in Germany
- Manufactured according to ISO 9001 and ISO 14001

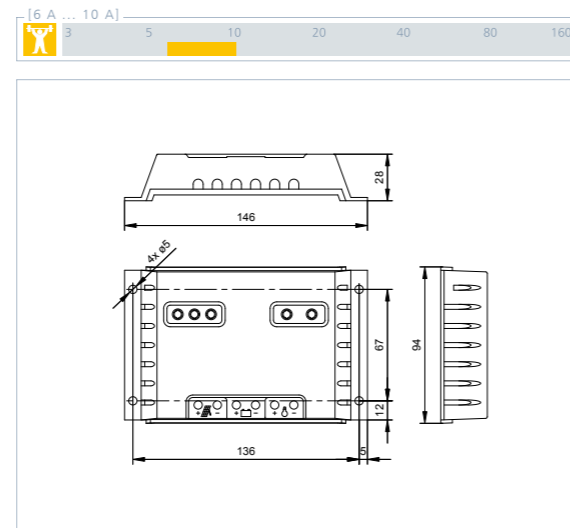

	PR 0606N	PR 1010N
Characterisation of the operating performance		
System voltage	12 V (24 V)	
Own consumption	6 mA	
DC input side		
Open circuit voltage solar module	< 47 V	
Module current	6 A	10 A
DC output side		
Load current	6 A	10 A
End of charge voltage	13.7 V (27.4 V)	
Boost charge voltage	14.4 V (28.8 V)	
Equalisation charge	14.7 V or 15 V (29.4 V)	
Reconnection voltage (SOC / LVR)	> 50 % / 12.6 V (25.2 V)	
Deep discharge protection (SOC / LVD)	< 30 % / 11.1 V (22.2 V)	
Operating conditions		
Ambient temperature	-25 °C ... +50 °C	
Fitting and construction		
Terminal (fine / single wire)	6 mm ² / 10 mm ² - AWG 10 / 8	
Degree of protection	IP 22	
Dimensions (X x Y x Z)	146 x 94 x 28 mm	
Weight	120 g	
Night-light function	19 h ... 3 h	
Morning-light function	23 h ... 7 h	

Technical data at 25 °C / 77 °F

Steca PR

PR 1010, PR 1515, PR 2020, PR 3030

The Steca PR 10-30 series of charge controllers is the high-light in the range.

The latest charging technologies, combined with a Steca-AtonIC state of charge determination which has been significantly improved once again, result in optimal battery maintenance and control of the module output of up to 900 Wp which can be connected to it. A large display informs the user about all operating modes with the aid of symbols. The state of charge is represented visually in the form of a tank display. Data such as voltage, current and state of charge can also be displayed digitally as figures on the display. In addition, the controller has an energy meter which can be reset by the user.

Product features

- Hybrid controller
- State of charge determination with Steca AtonIC (SOC)
- Automatic detection of voltage
- PWM control
- Multistage charging technology
- Load disconnection depending on SOC
- Automatic load reconnection
- Temperature compensation
- Common positive grounding or negative grounding on one terminal
- Integrated data logger
- Night light function
- Integrated self test
- Monthly maintenance charge

Electronic protection functions

- Overcharge protection
- Deep discharge protection
- Reverse polarity protection of load, module and battery
- Automatic electronic fuse
- Short circuit protection of load and module
- Overvoltage protection at module input
- Open circuit protection without battery
- Reverse current protection at night
- Overtemperature and overload protection
- Battery overvoltage shutdown

Displays

- Graphical LCD display – for operating parameters, fault messages, self test

Operation

- Simple menu-driven operation
- Programming by buttons
- Manual load switch

Options

- Prepayment interface
- External temperature sensor
- Alarm contact

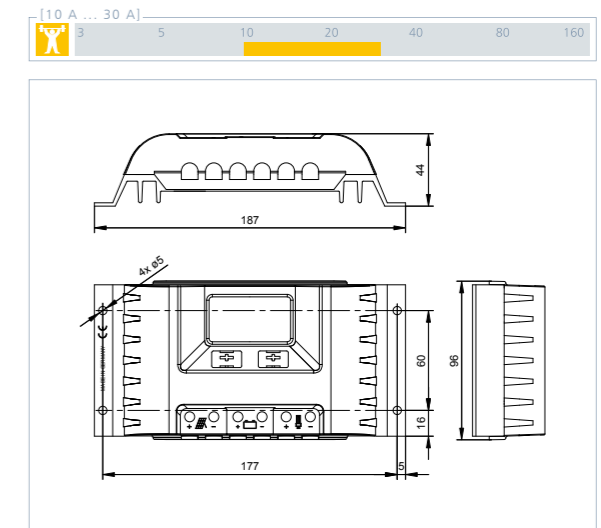

	PR 1010	PR 1515	PR 2020	PR 3030
Characterisation of the operating performance				
System voltage	12 V (24 V)			
Own consumption	12.5 mA			
DC input side				
Open circuit voltage solar module	< 47 V			
Module current	10 A	15 A	20 A	30 A
DC output side				
Load current	10 A	15 A	20 A	30 A
End of charge voltage	liquid 13.9 V (27.8 V); gel 14.1 V (28.2 V)			
Boost charge voltage	14.4 V (28.8 V)			
Equalisation charge	14.7 V (29.4 V)			
Reconnection voltage (SOC / LVR)	> 50 % / 12.6 V (25.2 V)			
Deep discharge protection (SOC / LVD)	< 30 % / 11.1 V (22.2 V)			
Operating conditions				
Ambient temperature	-10 °C ... +50 °C			
Fitting and construction				
Terminal (fine / single wire)	16 mm ² / 25 mm ² - AWG 6 / 4			
Degree of protection	IP 32			
Dimensions (X x Y x Z)	187 x 96 x 44 mm			
Weight	350 g			

Technical data at 25 °C / 77 °F

Certificates

- Approved by the World Bank for Nepal
- Compliant with European Standards (CE)
- RoHS compliant
- Made in Germany
- Developed in Germany
- Manufactured according to ISO 9001 and ISO 14001

[areas of application]



[areas of application]



Steca PR 2020 IP

IP 65 version

The functionality of the Steca PR 2020 IP is based on the Steca PR line of solar charge controllers.

This is equipped with a large display which shows the current state of charge (SOC) as a percentage and graphically in the form of a tank. The key component of the charge controller is the state of charge determination, which has been significantly improved. The auto-adaptive state of charge algorithm results in optimal battery maintenance and control over the module output of up to 480 Wp which can be connected to it. The Steca PR 2020 IP has been specially designed for operation in difficult environments with high salt, moisture and dust content.

Product features

- Hybrid controller
- State of charge determination with Steca AtonIC (SOC)
- Automatic detection of voltage
- PWM control
- Multistage charging technology
- Load disconnection depending on SOC
- Automatic load reconnection
- Temperature compensation
- Common positive grounding or negative grounding on one terminal
- Integrated data logger
- Night light function
- Integrated self test
- Monthly maintenance charge
- Integrated energy meter

Electronic protection functions

- Overcharge protection
- Deep discharge protection
- Reverse polarity protection of load, module and battery
- Automatic electronic fuse
- Short circuit protection of load and module
- Overvoltage protection at module input
- Open circuit protection without battery
- Reverse current protection at night
- Overtemperature and overload protection
- Battery overvoltage shutdown

Displays

- Graphical LCD display
- for operating parameters, fault messages, self test

Operation

- Programming by buttons
- Manual load switch

Options

- External temperature sensor
- Alarm contact

Certificates

- Fit for use in tropical areas (DIN IEC 68 part 2-30)
- Compliant with European Standards (CE)
- RoHS compliant
- Made in Germany
- Developed in Germany
- Manufactured according to ISO 9001 and ISO 14001

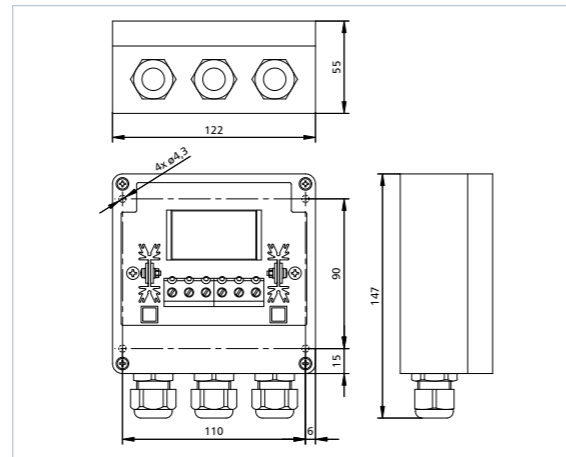
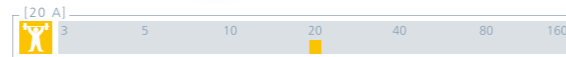

	PR 2020-IP
Characterisation of the operating performance	
System voltage	12 V (24 V)
Own consumption	12 mA
DC input side	
Open circuit voltage solar module	< 47 V
Module current	20 A
DC output side	
Load current	20 A
End of charge voltage	liquid 13.9 V (27.8 V); gel 14.1 V (28.2 V)
Boost charge voltage	14.4 V (28.8 V)
Equalisation charge	14.7 V (29.4 V)
Reconnection voltage (SOC / LVR)	> 50 % / 12.6 V (25.2 V)
Deep discharge protection (SOC / LVD)	< 30 % / 11.1 V (22.2 V)
Operating conditions	
Ambient temperature	-10 °C ... +50 °C
Fitting and construction	
Terminal (fine / single wire)	16 mm ² / 25 mm ² - AWG 6 / 4
Degree of protection	IP 65
Dimensions (X x Y x Z)	122 x 147 x 55 mm
Weight	350 g

Technical data at 25 °C / 77 °F

Steca Solarix PRS

PRS 1010, PRS 1515, PRS 2020, PRS 3030

The simplicity and high performance of the Steca Solarix PRS solar charge controller make it particularly appealing. At the same time, it offers a modern design and a convenient display, all at an extremely attractive price.

Several LEDs in various colours emulate a tank display, which gives information on the battery's state of charge. Here, Steca's latest algorithms are employed, resulting in optimal battery maintenance. The Solarix PRS charge controllers are equipped with an electronic fuse, thus making optimal protection possible. They operate on the serial principle, and separate the solar module from the battery in order to protect it against overcharging.

For larger projects, the charge controllers can also be equipped with special functions: e.g. with night light function and selectable charging plateau and deep-discharge protection voltages.

Product features

- Series controller
- Automatic detection of voltage
- Voltage and current regulation
- PWM control
- Multistage charging technology
- Current compensated load disconnection
- Automatic load reconnection
- Temperature compensation
- Common positive grounding or negative grounding on one terminal
- Integrated self test
- Monthly maintenance charge

Electronic protection functions

- Overcharge protection
- Deep discharge protection
- Reverse polarity protection of load, module and battery
- Automatic electronic fuse
- Short circuit protection of load and module
- Overvoltage protection at module input
- Open circuit protection without battery
- Reverse current protection at night
- Overtemperature and overload protection
- Battery overvoltage shutdown

Displays

- Multifunction LED display
- Multi-coloured LED
- 5 LEDs show operating states
- for operation, state of charge, fault messages

Options

- Night light function pre-set in the factory or adjustable via Steca PA RC 100
- Parameterisation of function values via Steca PA RC 100

Certificates

- Compliant with European Standards (CE)
- RoHS compliant
- Made in Germany
- Developed in Germany
- Manufactured according to ISO 9001 and ISO 14001

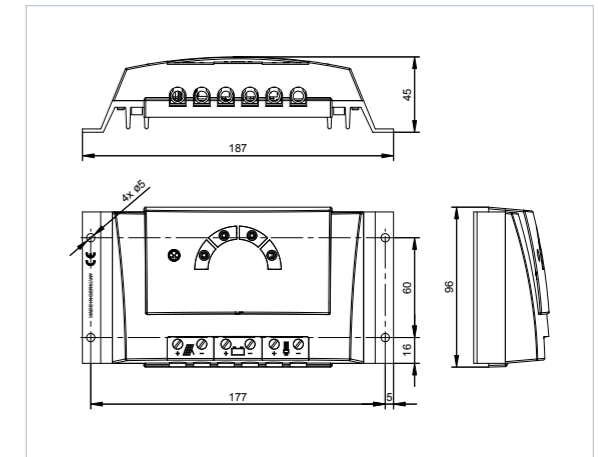
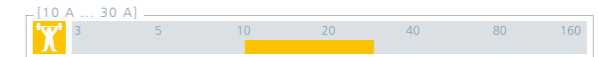

	PRS 1010	PRS 1515	PRS 2020	PRS 3030
Characterisation of the operating performance				
System voltage	12 V (24 V)			
Own consumption	< 4 mA			
DC input side				
Open circuit voltage solar module	< 47 V			
Module current	10 A	15 A	20 A	30 A
DC output side				
Battery voltage	9 V ... 17 V (17.1 V ... 34 V)			
Load current	10 A	15 A	20 A	30 A
End of charge voltage	13.9 V (27.8 V)			
Boost charge voltage	14.4 V (28.8 V)			
Equalisation charge	14.7 V (29.4 V)			
Reconnection voltage (SOC / LVR)	> 50 % / 12.4 V ... 12.7 V (24.8 V ... 25.4 V)			
Deep discharge protection (SOC / LVD)	< 30 % / 11.2 V ... 11.6 V (22.4 V ... 23.2 V)			
Operating conditions				
Ambient temperature	-25 °C ... +50 °C			
Fitting and construction				
Terminal (fine / single wire)	16 mm ² / 25 mm ² - AWG 6 / 4			
Degree of protection	IP 32			
Dimensions (X x Y x Z)	187 x 96 x 45 mm			
Weight	345 g			

Technical data at 25 °C / 77 °F



Remote control Steca PA RC100 (page 54)

[areas of application]



[areas of application]



Steca Solarix MPPT

MPPT 2010

Steca Solarix MPPT 2010 is a solar charge controller with Maximum Power Point Tracking. It is specially designed to work with all established module technologies and is optimized for solar systems with module voltages higher than the battery voltage. The Steca Solarix MPPT 2010 is especially qualified in combination with grid tied solar modules. The advanced MPP-tracking algorithm from Steca assures that the maximum available power of the solar generator is charged to the batteries. The Steca Solarix MPPT 2010 with latest technology ensures full performance in all conditions, a professional battery care combined with modern design and excellent protection.

Product features

- Maximum Power Point Tracker (MPP tracker)
- Voltage and current regulation
- PWM control
- Current compensated load disconnection
- Automatic load reconnection
- Temperature compensation
- Monthly maintenance charge

Electronic protection functions

- Overcharge protection
- Deep discharge protection
- Reverse polarity protection of load, module and battery
- Reverse polarity protection by internal fuse
- Automatic electronic fuse
- Short circuit protection
- Overvoltage protection at module input
- Open circuit protection without battery
- Reverse current protection at night
- Overtemperature and overload protection
- Battery overvoltage shutdown

Displays

- Multifunction LED display
- Multi-coloured LED
- 5 LEDs show operating states
- for operation, state of charge, fault messages

Options

- Night light function pre-set in the factory or adjustable via Steca PA RC 100
- Parameterisation of function values via Steca PA RC 100

Certificates

- Compliant with European Standards (CE)
- RoHS compliant
- Made in Germany
- Developed in Germany
- Manufactured according to ISO 9001 and ISO 14001



Remote control
Steca PA RC100
(page 54)

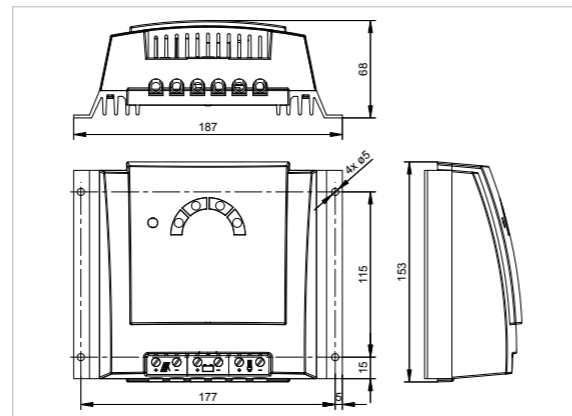

MPPT	
Characterisation of the operating performance	
System voltage	12 V (24 V)
Nominal power	250 W (500 W)
Max. efficiency	> 98 %
Own consumption	10 mA
DC input side	
MPP voltage	15 V (30 V) <math>< V_{\text{module}} < < 100 \text{ V}</math>
Open circuit voltage solar module **	17 V ... 100 V (34 V ... 100 V)
(at minimum operating temperature)	
Module current	18 A
DC output side	
Charge current	20 A
Load current	10 A
End of charge voltage*	13.9 V (27.8 V)
Boost charge voltage*	14.4 V (28.8 V)
Equalisation charge*	14.7 V (29.4 V)
Reconnection voltage* (LVR)	12.5 V (25 V)
Deep discharge protection* (LVD)	11.5 V (23 V)
Operating conditions	
Ambient temperature	-25 °C ... +40 °C
Fitting and construction	
Terminal (fine / single wire)	16 mm ² / 25 mm ² - AWG 6 / 4
Degree of protection	IP 32
Dimensions (X x Y x Z)	187 x 153 x 68 mm
Weight	approx. 900 g

**CAUTION: If an open circuit voltage of more than 100 V is supplied to the connected solar module, the controller will be destroyed. When selecting the solar module, it is important to bear in mind that the open circuit voltage should never exceed 100 V over the entire working temperature range. When using solar modules with a maximum open circuit voltage of between 75 and 100 V (over the entire temperature range), all installation steps must be carried in accordance with protection class II.

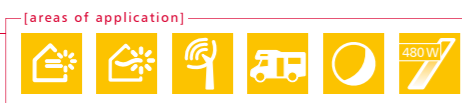
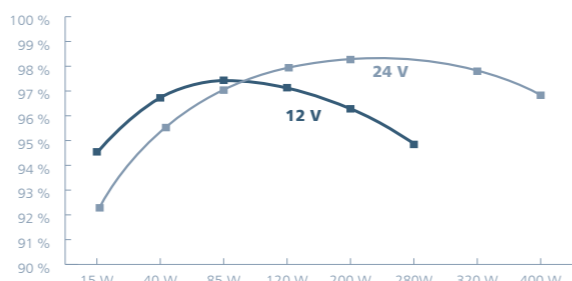

Steca Solarix

2401, 4401

The solar charge controllers Steca Solarix 2401 and 4401 are optimally suited for inverter systems. The controller combines basic solar charger functions with a 40 A high-performance charge controller. It is available as 12 V / 24 V and 48 V system. This makes the solar charge controller very cost effective.

The load current is limited to 10 A. The charging processes are based on the voltage level, which can be individually set with the help of four buttons behind the front casing.

Product features

- Hybrid controller
- Voltage regulation
- Automatic detection of voltage
- PWM control
- Multistage charging technology
- Load disconnection depending on voltage
- Automatic load reconnection
- Temperature compensation
- Common positive grounding or negative grounding on one terminal
- Integrated self test
- Monthly maintenance charge

Electronic protection functions

- Overcharge protection
- Deep discharge protection
- Reverse polarity protection of load, module and battery
- Reverse polarity protection by internal fuse
- Automatic electronic fuse
- Short circuit protection of load and module
- Overvoltage protection at module input
- Open circuit protection without battery
- Reverse current protection at night
- Overtemperature and overload protection
- Battery overvoltage shutdown

Displays

- Text LCD display
- for operating parameters, fault messages, self test

Operation

- Simple menu-driven operation
- Programming by buttons
- Manual load switch

Interfaces

- RJ45 interface

Options

- External temperature sensor
- Alarm contact

Certificates

- Compliant with European Standards (CE)
- Made in Germany
- Developed in Germany
- Manufactured according to ISO 9001 and ISO 14001

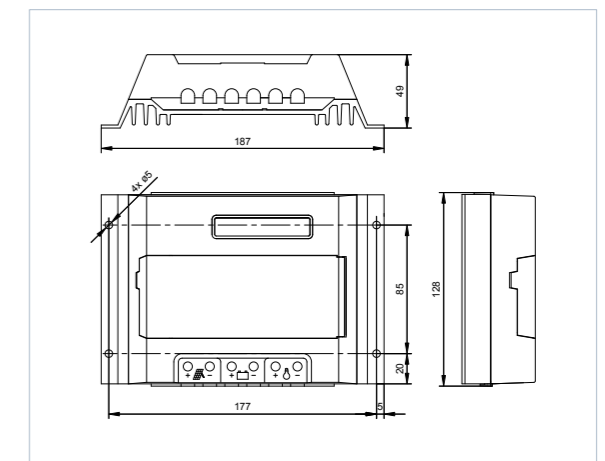
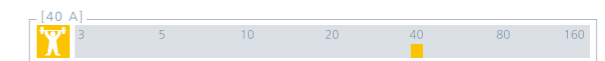
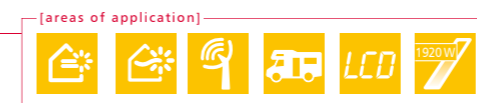

	2401	4401
Characterisation of the operating performance		
System voltage	12 V (24 V)	48 V
Own consumption	14 mA	
DC input side		
Module current	40 A	
DC output side		
Load current	10 A	
End of charge voltage	13.7 V (27.4 V)	54.8 V
Boost charge voltage	14.4 V (28.8 V)	57.6 V
Equalisation charge	14.7 V (29.4 V)	58.8 V
Reconnection voltage (LVR)	12.6 V (25.2 V)	50.4 V
Deep discharge protection (LVD)	11.1 V (22.2 V)	44.4 V
Operating conditions		
Ambient temperature	-10 °C ... +60 °C	
Fitting and construction		
Terminal (fine / single wire)	16 mm ² / 25 mm ² - AWG 6 / 4	
Degree of protection	IP 32	
Dimensions (X x Y x Z)	187 x 128 x 49 mm	
Weight	550 g	

Technical data at 25 °C / 77 °F

programmable

Steca Tarom

235, 245, 440

The Steca Tarom is a solar charge controller specifically designed for use in telecommunications applications or in hybrid photovoltaic systems.

Numerous clever functions allow the user to adjust the controller to the particular features of the system in question. Thanks to the significantly improved state of charge determination, the system is optimally controlled and batteries are protected. The Steca Tarom charge controller is the best choice for system sizes of up to 2400 Wp at three voltage levels (12 V, 24 V, 48 V).

There is the option of connecting additional devices such as a temperature sensor, a data logger and a remote control for configuring and monitoring the system. An integrated Ah meter also provides the user with information on the energy budget of the application.

Product features

- Hybrid controller
- State of charge determination with Steca AtonIC (SOC)
- Automatic detection of voltage
- PWM control
- Multistage charging technology
- Load disconnection depending on SOC
- Automatic load reconnection
- Temperature compensation
- Common positive grounding or negative grounding on one terminal
- Integrated data logger
- Night light function with Steca PA 15
- Integrated self test
- Monthly maintenance charge
- Integrated energy meter

Electronic protection functions

- Overcharge protection
- Deep discharge protection
- Reverse polarity protection of load and module
- Reverse polarity protection by internal fuse
- Automatic electronic fuse
- Short circuit protection of load and module
- Overvoltage protection at module input
- Open circuit protection without battery
- Reverse current protection at night
- Overtemperature and overload protection
- Battery overvoltage shutdown

Displays

- Text LCD display
- for operating parameters, fault messages, self test

Operation

- Simple menu-driven operation
- Programming by buttons
- Manual load switch

Interfaces

- RJ45 interface

Options

- External temperature sensor
- Alarm contact

Certificates

- Approved by the World Bank for Nepal
- Compliant with European Standards (CE)
- Made in Germany
- Developed in Germany
- Manufactured according to ISO 9001 and ISO 14001

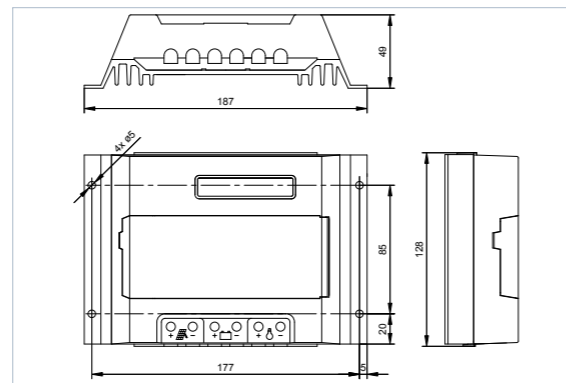
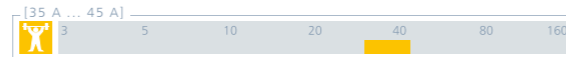

	235	245	440
Characterisation of the operating performance			
System voltage	12 V (24 V)		48 V
Own consumption	14 mA		
DC input side			
Module current	35 A	45 A	40 A
DC output side			
Load current	35 A	45 A	40 A
End of charge voltage	13.7 V (27.4 V)		54.8 V
Boost charge voltage	14.4 V (28.8 V)		57.6 V
Equalisation charge	14.7 V (29.4 V)		58.8 V
Reconnection voltage (SOC / LVR)	> 50 % / 12.6 V (25.2 V)		> 50 % / 50.4 V
Deep discharge protection (SOC / LVD)	< 30 % / 11.1 V (22.2 V)		< 30 % / 44.4 V
Operating conditions			
Ambient temperature	-10 °C ... +60 °C		
Fitting and construction			
Terminal (fine / single wire)	16 mm ² / 25 mm ² - AWG 6 / 4		
Degree of protection	IP 32		
Dimensions (X x Y x Z)	187 x 128 x 49 mm		
Weight	550 g		

Technical data at 25 °C / 77 °F



Steca PA Tarcom Data logger
(page 50)



Steca PA HS200 Shunt
(page 51)



Steca PA 15 Remote control
(page 52)



Steca Power Tarom

2070, 2140, 4055, 4110, 4140

Specially designed for industrial and outdoor applications, the Steca Power Tarom comes with an IP 65 casing made of powder-coated steel.

This solar charge controller can be used to control system sizes of up to 8400 Wp at three voltage levels (12 V, 24 V, 48 V). The Steca Power Tarom is based on the technology of the Steca Tarom controller. When connected in parallel, several controllers from this series can be operated via a standard DC bus in a simple solar home system or a hybrid system. This allows an output of over 20 kWp to be reached.

Product features

- Hybrid controller
- State of charge determination with Steca AtonIC (SOC)
- Automatic detection of voltage
- PWM control
- Multistage charging technology
- Load disconnection depending on SOC
- Automatic load reconnection
- Temperature compensation
- Common positive grounding or negative grounding on one terminal
- Integrated data logger
- Night light function with Steca PA 15
- Integrated self test
- Monthly maintenance charge
- Integrated energy meter

Electronic protection functions

- Overcharge protection
- Deep discharge protection
- Reverse polarity protection of load, module and battery
- Reverse polarity protection by internal fuse
- Automatic electronic fuse
- Short circuit protection of load and module
- Overvoltage protection at module input
- Open circuit protection without battery
- Reverse current protection at night
- Overtemperature and overload protection
- Battery overvoltage shutdown

Displays

- Text LCD display
- for operating parameters, fault messages, self test

Operation

- Simple menu-driven operation
- Programming by buttons
- Manual load switch

Interfaces

- RJ45 interface

Options

- External temperature sensor
- Alarm contact

Certificates

- Approved by the World Bank for Nepal
- Fit for use in tropical areas (DIN IEC 68 part 2-30)
- Compliant with European Standards (CE)
- Made in Germany
- Developed in Germany
- Manufactured according to ISO 9001 and ISO 14001

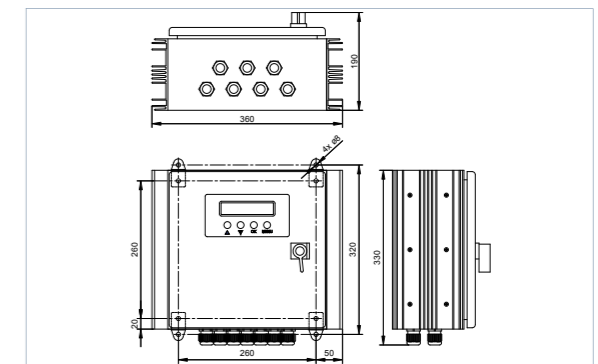
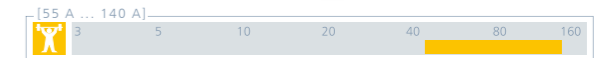

Steca Power Tarom 2140, Power Tarom 4110, Power Tarom 4140

	2070	2140	4055	4110	4140
Characterisation of the operating performance					
System voltage	12 V (24 V)		48 V		
Own consumption	14 mA				
DC input side					
Open circuit voltage solar module	< 50 V		< 100 V		
Module current	70 A	140 A	55 A	110 A	140 A
DC output side					
Load current	70 A	70 A	55 A	55 A	70 A
End of charge voltage	13.7 V (27.4 V)		54.8 V		
Boost charge voltage	14.4 V (28.8 V)		57.6 V		
Equalisation charge	14.7 V (29.4 V)		58.8 V		
Reconnection voltage (SOC / LVR)	> 50 % / 12.6 V (25.2 V)		> 50 % / 50.4 V		
Deep discharge protection (SOC / LVD)	< 30 % / 11.1 V (22.2 V)		< 30 % / 44.4 V		
Operating conditions					
Ambient temperature	-10 °C ... +60 °C				
Fitting and construction					
Terminal (fine / single wire)	50 mm ² - AWG 1	95 mm ² - AWG 000	50 mm ² - AWG 1	70 mm ² - AWG 00	95 mm ² - AWG 000
Degree of protection	IP 65				
Dimensions (X x Y x Z)	330 x 330 x 190 mm	360 x 330 x 190 mm	330 x 330 x 190 mm	360 x 330 x 190 mm	
Weight	10 kg				

Technical data at 25 °C / 77 °F



Steca PA Tarcom Data logger
(page 50)



Steca PA HS200 Shunt
(page 51)



Steca PA 15 Remote control
(page 52)



Steca PL 2085

Solar charging point

The Steca PL 2085 solar charging point is a highly intelligent maximum power point tracker which is able to charge eight batteries with different states of charge at the same time.

On the input side, the Steca PL 2085 is fed by a 24 V module array of up to 800 Wp. Every charge channel operates fully independently; it is also possible to connect different batteries with various states of charge. The battery which is connected first is also the first to be charged. The display can show the system data for each individual battery. There is a maximum of 5 A available per charging channel, and a maximum of four channels can be connected in parallel at once, so that two batteries with 20 A each can also be charged. Thanks to the reverse polarity protection, electronic fuse and automatic detection of a faulty battery, the device is maintenance-free and user-friendly.

Product features

- Maximum Power Point Tracker (MPP tracker)
- Charger for 8 batteries
- Up to 4 channels can be connected in parallel
- Special maintenance charge
- Integrated energy meter for every channel
- Temperature compensation

Electronic protection functions

- Overcharge protection
- Reverse polarity protection
- Automatic electronic fuse
- Short circuit protection
- Overvoltage protection at module input
- Open circuit protection without battery
- Reverse current protection at night
- Overtemperature and overload protection

Displays

- Every single battery station
- Text LCD display
 - for voltage, current, charged capacity, state of charge
 - for operating parameters, fault messages, self test

Operation

- Battery selection and charge stop via rotary switch

Certificates

- Compliant with European Standards (CE)
- Made in Germany
- Developed in Germany
- Manufactured according to ISO 9001 and ISO 14001

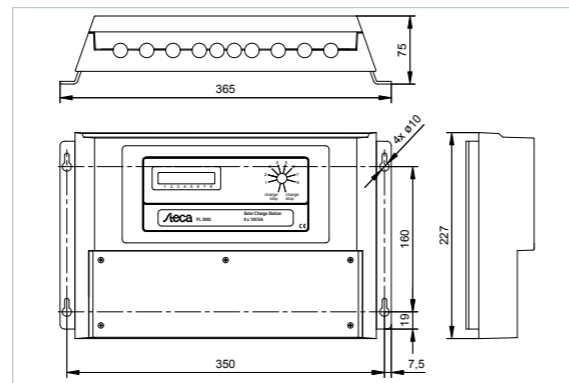
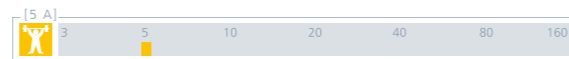

	PL 2085
Characterisation of the operating performance	
System voltage	12 V
DC input side	
Recommended module output for 24 V system	200 Wp ... 1,000 Wp
DC output side	
End of charge voltage	13.8 V
Boost charge voltage	14.7 V
Number of charging points	8
Permitted current per connection	5 A
Operating conditions	
Ambient temperature	-20 °C ... +50 °C
Fitting and construction	
Terminal (fine / single wire)	16 mm ² / 25 mm ² - AWG 6 / 4
Degree of protection	IP 54
Dimensions (X x Y x Z)	365 x 227 x 75 mm
Weight	2 kg

Technical data at 25 °C / 77 °F



Steca Solarix PI

550, 550-L60, 1100, 1100-L60

In developing the Solarix PI sine wave inverter, Steca has brought about some innovations which are unprecedented in this form. These are, above all, parallel connection, the novel operating concept which uses a single rotary switch, direct communication in order to calculate the state of charge (SOC) with Steca Tarom and Steca Power Tarom, and the electronic fuse. Furthermore, our many years of experience have come into play for deploying these inverters specifically in photo-voltaic systems. This comes through, for instance, in the way that a most diverse range of appliances is provided with a low operating consumption and a stable energy supply.

Product features

- True sine wave voltage
- Can be connected to the Steca Tarom with a Steca PAx4 parallel switch box
- Excellent overload capabilities
- Optimal battery protection
- Automatic load detection
- Parallel connectable
- Best reliability
- Protective insulation according to protection class II
- Control by digital signal processor (DSP)

Electronic protection functions

- Deep discharge protection
- Battery overvoltage shutdown
- Overtemperature and overload protection
- Short circuit protection
- Reverse polarity protection
- Automatic electronic fuse

Displays

- Multi-coloured LED shows operating states

Operation

- Main switch
- Adjustable load detection

Certificates

- Compliant with European Standards (CE)
- Made in Germany
- Developed in Germany
- Manufactured according to ISO 9001 and ISO 14001

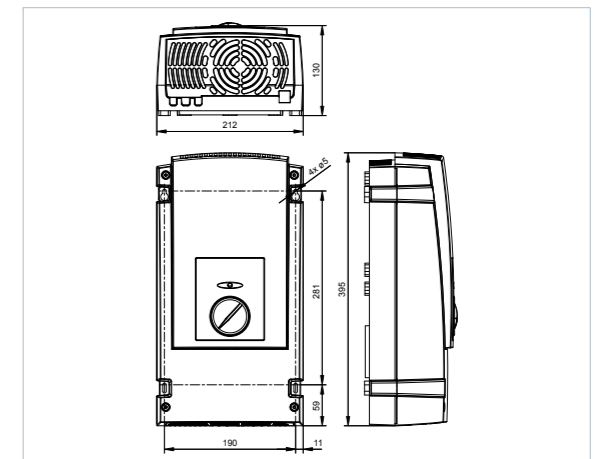

	550	550-L60	1100	1100-L60
Characterisation of the operating performance				
System voltage	12 V		24 V	
Continuous power	500 VA		1,000 VA	
Power 30 min.	550 VA		1,110 VA	
Power 5 sec.	1,500 VA		3,000 VA	
Power asymmetric	350 VA		500 VA	
Max. efficiency	93 %		94 %	
Own consumption standby / ON	0.5 W / 6 W		0.7 W / 10 W	
DC input side				
Battery voltage	10.5 V ... 16 V		21 V ... 32 V	
Reconnection voltage (LVR)	12.5 V		25 V	
Deep discharge protection (LVD)	current driven or by Tarom			
AC output side				
Output voltage	230 V AC +/-10 %	115 V AC +/-10 %	230 V AC +/-10 %	115 V AC +/-10 %
Output frequency	50 Hz	60 Hz	50 Hz	60 Hz
Load detection (standby)	adjustable: 2 W ... 50 W			
Safety				
Safety class	II (double insulated)			
Electrical protection	reverse polarity battery, reverse polarity AC, over voltage, over current, over temperature			
Operating conditions				
Ambient temperature	-20 °C ... +50 °C			
Fitting and construction				
Cable length battery / AC	1.5 m / 1.5 m			
Cable cross-section battery / AC	16 mm ² / 1.5 mm ²			
Degree of protection	IP 20			
Dimensions (X x Y x Z)	212 x 395 x 130 mm			
Weight	6.6 kg		9 kg	

Technical data at 25 °C / 77 °F



Steca Solarix PI: flexible and versatile

Parallel connection

A stand-alone PV system is relatively difficult to size, since often the loads and their average running times are not adequately known, or because, when the system is subsequently expanded, more loads are added.

This is where the simple expandability of the Steca Solarix PI inverters pays off. Up to four devices can be operated in parallel. The connections are made via an external box, the Steca PAX4.

From the outside, the combination of two, three or four inverters functions like one device with a correspondingly higher capacity. Internally, in case of open-circuit operation or low output, e.g. for the lighting, only one inverter continues to operate. This has a positive effect on the electricity consumption, since the devices which are not turned on do not consume any power. Only when a higher capacity is called for, for example when a refrigerator is turned on, are all the inverters automatically switched on, thus ensuring trouble-free operation.

In this regard, Steca Solarix PI inverters are all the same. Only via the connection to the Steca PAX4 parallel switch box is one inverter designated as the master. This device then has control over the system, whilst the other Steca Solarix PI inverters operate as slaves.



Rotary switch

Operating the Steca Solarix PI is made very easy by the large rotary switch on the front of the device.

If the Steca Solarix PI is being used as a single device, three different modes of operation are possible, and these may be selected using the rotary switch. The load detection section follows on from the 'off' setting on the far left. In this section, the switch can be turned continuously to match the power consumption of the smallest load. In order to reduce power consumption, the inverter is then turned off, and it checks periodically whether a load has been turned on. Only if this is the case does the inverter switch itself on. The 'on' setting on the rotary switch follows on from the load detection section. In this operating status, the inverter makes the output voltage continually available.

If several inverters are connected in parallel, the desired mode of operation is selected using the rotary switch of the device connected to the 'master socket'. In addition to the modes of operation described above, there is also the setting 'all on'. This means that not only the master device is continually switched on, but all other connected inverters as well.

The use of the rotary switch makes it possible to see very quickly which mode of operation the inverter is in.

Electronic fuse

One innovation in sine wave inverters is the electronic fuse as it is employed by Steca in solar charge controllers. With this fuse, the Steca Solarix PI is protected against overloads, and also against the accidental connection of the AC output to the public grid. Because the fuse is electronic, it does not need to be replaced after it has been triggered, as is the case with mechanical fuses. As soon as the problem has been remedied, the inverter automatically reverts back to its selected mode of operation.

The Steca Solarix PI is also internally protected against an incorrect wiring of the battery. In case of reverse polarity, the device remains undamaged, and there is no need to replace the fuse.

Quick and robust control

The Steca Solarix PI inverter was developed to supply power to a wide range of loads. Even critical loads can be operated, thanks to the quick control. At the heart of the controller is a DSP which takes on the extensive calculation work. The inverter's necessary robustness is supplied by a control software program which was developed in cooperation with a renowned research institute.

Low own consumption

In die Entwicklung des Sinus-Wechselrichters sind 15 Jahre The sine wave inverter has benefited from Steca's 15 years of experience in the field of stand-alone PV systems. This is reflected, for instance, in the low own consumption of the Steca Solarix PI. When used in solar home systems, the inverter is connected to the battery 24 hours a day, and is designed to consume as little as possible of the solar-generated energy whilst in load-detection or open-circuit modes.

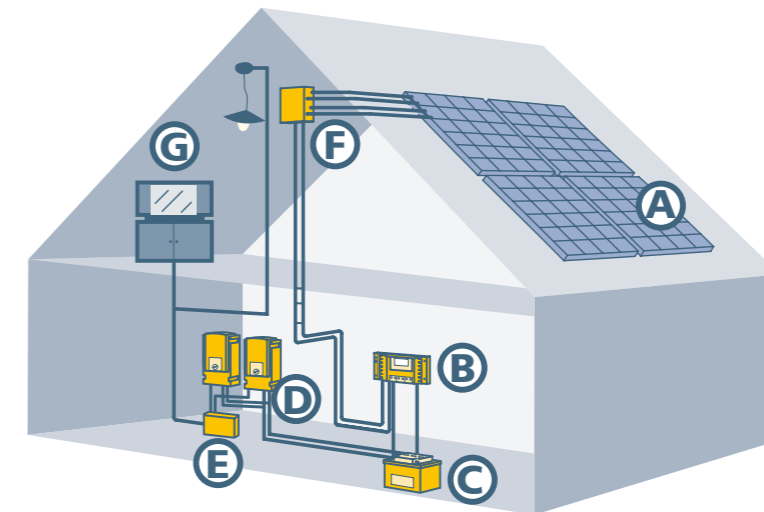

- Key:**
- A Solar module
 - B Solar charge controller
 - C Battery
 - D Steca Solarix PI sine wave inverter
 - E Steca PAX4 parallel switch box
 - F Generator junction box
 - G Electrical load (230 V-)

Steca Solarix PI with Steca Tarom

Communication with Steca Tarom solar charge controllers

A further innovation that has gone into the Steca Solarix PI is the communication with the solar charge controllers from the Steca Tarom and Steca Power Tarom series. A data connection to the charge controller can be created via the Steca PAX4 parallel switch box.

In this case, the inverter connected directly to the battery communicates the amount of energy that has been withdrawn to the solar charge controller. The controller is thus able to calculate the correct state of charge (SOC).

This means that these systems no longer need to be switched to voltage-controlled operation or an additional current shunt.

If the switch-off threshold of 30 % SOC is reached, the Steca Solarix PI receives a signal from the solar charge controller and subsequently switches itself off in order to protect the battery from deep discharge. It turns itself back on again once the SOC has reached the 50 % mark.

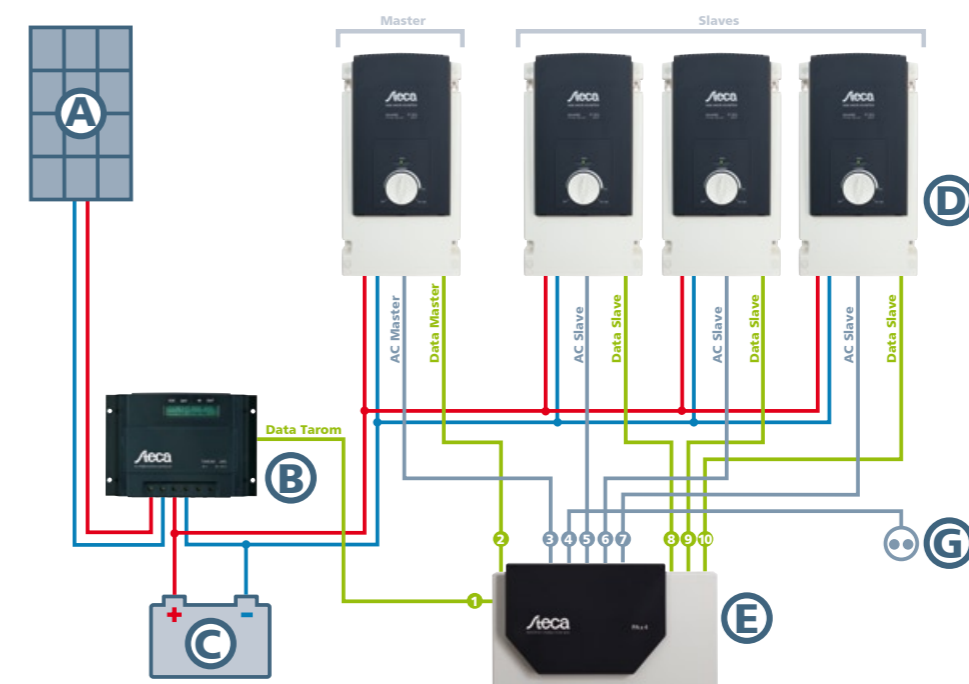

Steca AJ

275-12, 350-24, 400-48, 600-24, 700-48, 1000-12, 2100-12, 2400-24

The Steca AJ inverter series stands out with its wide range of available power classes and DC input voltages.

This enables the optimal inverter to be used for any application. The cables for connecting the battery and the load are already mounted on the Steca AJ, thus making it easier to install the device. The automatic standby mode considerably reduces the inverter's own consumption. The Steca AJ inverter's excellent overload capacity ensures that even critical loads can be operated easily.

Product features

- True sine wave voltage
- Excellent overload capabilities
- Optimal battery protection
- Automatic load detection
- Best reliability

Electronic protection functions

- Deep discharge protection
- Battery overvoltage shutdown
- Overtemperature and overload protection
- Short circuit protection
- Reverse polarity protection by internal fuse (except Steca AJ 2100-12)
- Acoustic alarm at deep discharge or overheating

Displays

- Multi-coloured LED shows operating states

Operation

- Main switch
- Adjustable load detection

Options

- Types with 115 V / 50 Hz, 115 V / 60 Hz or 230 V / 60 Hz
- Model with protective lacquered mainboard
- Terminal for connection of a remote control (On/Off) for the types Steca AJ 275-12 to Steca AJ 700-48
- Remote control JT8 (On/Off, LED) for connection to Steca AJ 1000-12 to Steca AJ 2400-24

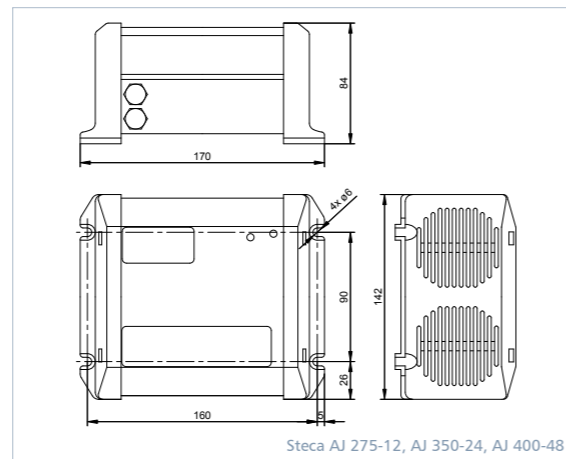
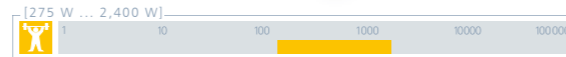

Steca AJ 275-12, AJ 350-24, AJ 400-48

Certificates

- Compliant with European Standards (CE)
- RoHS compliant

	275-12	350-24	400-48	600-24	700-48	1000-12	2100-12	2400-24
Characterisation of the operating performance								
System voltage	12 V	24 V	48 V	24 V	48 V	12 V	12 V	24 V
Continuous power	200 VA	300 VA	300 VA	500 VA	500 VA	800 VA	2,000 VA	2,000 VA
Power 30 min.	275 VA	350 VA	400 VA	600 VA	700 VA	1,000 VA	2,100 VA	2,400 VA
Power 5 sec.	450 VA	650 VA	1,000 VA	1,200 VA	1,400 VA	2,200 VA	5,000 VA	5,200 VA
Max. efficiency	93 %	94 %	94 %	94 %	94 %	93 %	92 %	94 %
Own consumption standby / ON	0.3 W / 2.4 W	0.5 W / 3.5 W	1.1 W / 5.2 W	0.6 W / 7.2 W	1.5 W / 12 W	0.7 W / 10 W	0.7 W / 16 W	1.2 W / 16 W
DC input side								
Battery voltage	10.5 V ... 16 V	21 V ... 32 V	42 V ... 64 V	21 V ... 32 V	42 V ... 64 V	10.5 V ... 16 V	10.5 V ... 16 V	21 V ... 32 V
AC output side								
Output voltage	230 V AC +0 / -10 % (true sine wave)							
Output frequency	50 Hz +/-0.05 % (crystal controlled)							
Load detection (standby)	2 W			adjustable: 1 W ... 20 W				
Operating conditions								
Ambient temperature	-20 °C ... +50 °C							
Fitting and construction								
Cable length battery / AC	1.2 m / 1 m			1.5 m / 1 m			1.7 m / 1 m	
Degree of protection	IP 30			IP 30			IP 20	
Dimensions (X x Y x Z)	170 x 142 x 84 mm			252 x 142 x 84 mm		455 x 142 x 84 mm		406 x 273 x 117 mm
Weight	2.4 kg		2.6 kg		4.5 kg		8.5 kg	19 kg

Technical data at 25 °C / 77 °F



Steca XPC

1400-12, 2200-24, 2200-48

The Steca XPC series of inverters combine a very high overload capacity with the capability to operate highly critical loads.

Other important features of these high-quality inverters are their powerful device protection and their low own consumption. The Steca XPCs combine a sine wave inverter, four-stage battery charger and transfer system in one device, therefore making them also suitable for hybrid systems. The built-in multifunctional contact enables you, for example, to switch on and off diversion loads for excess power or start a diesel generator to recharge batteries

Product features

- True sine wave voltage
- Excellent overload capabilities
- Optimal battery protection
- Adjustable integrated battery charger
- Automatic load detection
- Best reliability
- Can be used as a back-up system or uninterruptible power supply (UPS)
- Multifunction contact
- Ultra-fast transfer relay

Electronic protection functions

- Deep discharge protection
- Battery overvoltage shutdown
- Overtemperature and overload protection
- Short circuit protection
- Reverse polarity protection by internal fuse
- Acoustic alarm at deep discharge or overheating

Displays

- 7 LEDs show operating states
- for operation, fault messages

Operation

- Main switch
- Adjustable load detection
- Programming by buttons

Options

- Type with 230 V / 60 Hz
- Type with 115 V / 60 Hz
- Model with protective lacquered mainboard
- Protection cover C-IP23 to raise the degree of protection
- Remote control RCC-01
- CFC-01 cable entry for strain relief and protection of connections
- Temperature sensor CT35 to correct the voltage thresholds according to the current battery temperature

Certificates

- Compliant with European Standards (CE)
- RoHS compliant

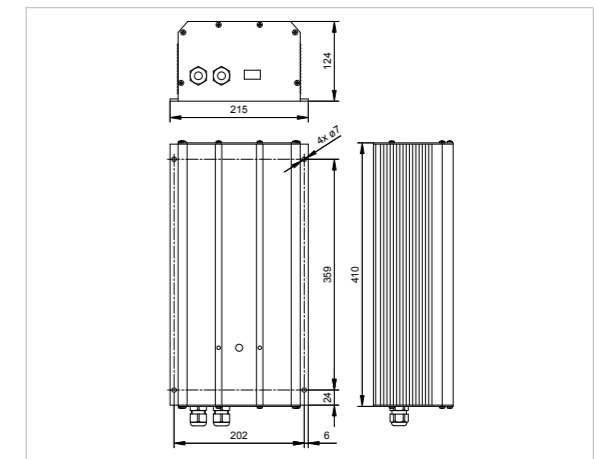

	1400-12	2200-24	2200-48
Characterisation of the operating performance			
System voltage	12 V	24 V	48 V
Continuous power	1,100 VA	1,600 VA	1,600 VA
Power 30 min.	1,400 VA	2,200 VA	2,200 VA
Power 5 sec.	3,300 VA	4,800 VA	4,800 VA
Max. efficiency	94 %	95 %	95 %
Own consumption standby / ON	0.6 W / 4 W	0.9 W / 7 W	1.3 W / 7 W
Input side			
Input voltage	adjustable: 150 V AC ... 230 V AC		
Charging current adjustable	0 A ... 45 A	0 A ... 37 A	0 A ... 20 A
Max. current on transfer system	16 A		
Switching time transfer relay	< 40 ms		
Battery side			
Battery voltage	9.5 V ... 16 V	19 V ... 32 V	38 V ... 64 V
Battery monitoring	LVD, HVD, floating and equalisation voltage adjustable by user via optional remote control RCC-01		
AC output side			
Output voltage	230 V AC +0 / -10 % (true sine wave)		
Output frequency	50 Hz +/-0.05 % (crystal controlled)		
Load detection (standby)	adjustable: 1 W ... 25 W		
Operating conditions			
Ambient temperature	-20 °C ... +55 °C		
Fitting and construction			
Cable length battery	165 cm		
Degree of protection	IP 20 / with optional top cover: IP 22		
Dimensions (X x Y x Z)	215 x 410 x 124 mm		
Weight	11.7 kg	12.6 kg	

Technical data at 25 °C / 77 °F

Steca Compact

1600-12, 2600-24, 4000-48

The Steca Compact series is specially designed for hybrid systems.

The devices consist of a sine wave inverter with a high overload capacity, a battery charger and a transfer system. The built-in multifunctional contact makes it possible, for example, to switch on and off diversion loads for excess power or start a diesel generator to recharge batteries. Even if you only use the device's sine wave inverter, the Steca Compact series is still very cost effective. The integrated power sharing function ensures that the transfer system always provides the connected loads with the desired power.



Product features

- True sine wave voltage
- Excellent overload capabilities
- Optimal battery protection
- Adjustable integrated battery charger
- Automatic load detection
- Best reliability
- Can be used as a back-up system or uninterruptible power supply (UPS)
- Multifunction contact
- Adjustable power sharing
- Ultra-fast transfer relay

Electronic protection functions

- Deep discharge protection
- Battery overvoltage shutdown
- Overtemperature and overload protection
- Short circuit protection
- Reverse polarity protection by internal fuse
- Acoustic alarm at deep discharge or overheating

Displays

- 17 LEDs show operating states
- for operation, state of charge, fault messages
- Display of power and charging current

Operation

- Main switch
- Adjustable load detection
- Programming by buttons

Options

- Type with 230 V / 60 Hz
- Model with protective lacquered mainboard
- Protection cover C-IP23 to raise the degree of protection
- Remote control RCC-01
- CFC-01 cable entry for strain relief and protection of connections
- Temperature sensor CT35 to correct the voltage thresholds according to the current battery temperature
- Remote control RPS-01 for the power sharing function

Certificates

- Compliant with European Standards (CE)
- RoHS compliant

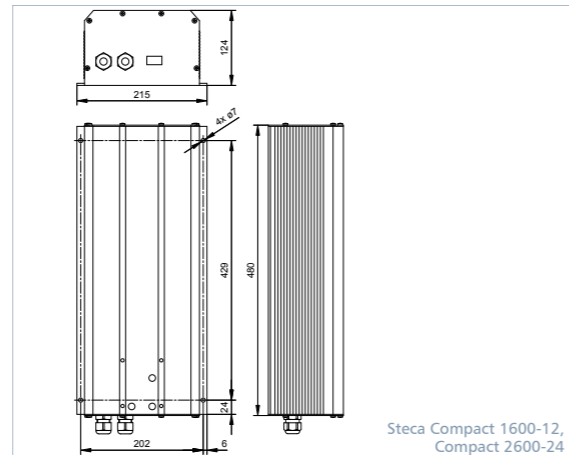

Steca Compact 1600-12, Compact 2600-24

	1600-12	2600-24	4000-48
Characterisation of the operating performance			
System voltage	12 V	24 V	48 V
Continuous power	1,300 VA	2,300 VA	3,500 VA
Power 30 min.	1,600 VA	2,600 VA	4,000 VA
Power 5 sec.	3,900 VA	6,900 VA	10,500 VA
Max. efficiency	94 %	95 %	95 %
Own consumption standby / ON	0.6 W / 6 W	0.9 W / 9 W	1.4 W / 12 W
Input side			
Input voltage	adjustable: 150 V AC ... 230 V AC		
Charging current adjustable	0 A ... 55 A	0 A ... 55 A	0 A ... 50 A
Max. current on transfer system	16 A		
Switching time transfer relay	< 40 ms		
Battery side			
Battery voltage	9.5 V ... 16 V	19 V ... 32 V	38 V ... 64 V
Battery monitoring	LVD, HVD, floating and equalisation voltage adjustable by user		
AC output side			
Output voltage	230 V AC +0 / -10 % (true sine wave)		
Output frequency	50 Hz +/-0.05 % (crystal controlled)		
Load detection (standby)	adjustable: 1 W ... 25 W		
Operating conditions			
Ambient temperature	-20 °C ... +55 °C		
Fitting and construction			
Input current repartition, „Power Sharing“	1 A ... 16 A		
Cable length battery	165 cm		
Degree of protection	IP 20 / with optional top cover: IP 22		
Dimensions (X x Y x Z)	215 x 480 x 124 mm	215 x 480 x 124 mm	215 x 670 x 124 mm
Weight	16 kg	17.1 kg	29.4 kg

Technical data at 25 °C / 77 °F

[areas of application]



Steca HPC

2800-12, 4400-24, 6000-48, 8000-48

The technology of the Steca HPC inverter series is based on Steca Compact devices. However, the four different types offer considerably greater power.

What's more, Steca HPC devices are equipped with PG cable glands for strain relief and protection of all connections. The devices consist of a sine wave inverter, a battery charger, a transfer system and a potential-free multifunctional contact. They are primarily used in hybrid systems. The integrated power sharing function ensures that the transfer system always provides the connected loads with the desired power.



Product features

- True sine wave voltage
- Excellent overload capabilities
- Optimal battery protection
- Adjustable integrated battery charger
- Automatic load detection
- Best reliability
- Can be used as a back-up system or uninterruptible power supply (UPS)
- Multifunction contact
- Adjustable power sharing
- Ultra-fast transfer relay

Electronic protection functions

- Deep discharge protection
- Battery overvoltage shutdown
- Overtemperature and overload protection
- Short circuit protection
- Reverse polarity protection by internal fuse
- Acoustic alarm at deep discharge or overheating

Displays

- 17 LEDs show operating states
- for operation, state of charge, fault messages
- Display of power and charging current

Operation

- Main switch
- Adjustable load detection
- Programming by buttons

Options

- Type with 230 V / 60 Hz
- Model with protective lacquered mainboard
- Remote control RCC-01
- Temperature sensor CT35 to correct the voltage thresholds according to the current battery temperature
- Remote control RPS-01 for the power sharing function

Certificates

- Compliant with European Standards (CE)
- RoHS compliant

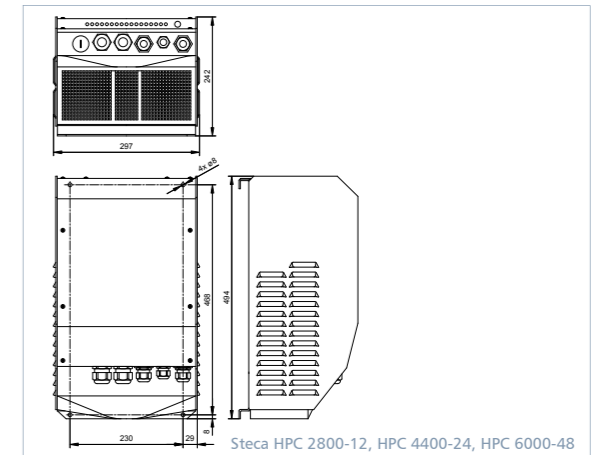

Steca HPC 2800-12, HPC 4400-24, HPC 6000-48

	2800-12	4400-24	6000-48	8000-48
Characterisation of the operating performance				
System voltage	12 V	24 V	48 V	48 V
Continuous power	2,500 VA	4,000 VA	5,000 VA	7,000 VA
Power 30 min.	2,800 VA	4,400 VA	6,000 VA	8,000 VA
Power 5 sec.	7,500 VA	12,000 VA	15,000 VA	21,000 VA
Max. efficiency	93 %	94 %	96 %	96 %
Own consumption standby / ON	1.8 W / 10 W	2 W / 16 W	2.5 W / 18 W	3 W / 30 W
Input side				
Input voltage	adjustable: 150 V AC ... 230 V AC			
Charging current adjustable	0 A ... 110 A	0 A ... 100 A	0 A ... 70 A	0 A ... 90 A
Max. current on transfer system	30 A		50 A	
Switching time transfer relay	< 40 ms			
Battery side				
Battery voltage	9.5 V ... 17 V	19 V ... 34 V	38 V ... 68 V	38 V ... 68 V
Battery monitoring	LVD, HVD, floating and equalisation voltage adjustable by user			
AC output side				
Output voltage	230 V AC +0 / -10 % (true sine wave)			
Output frequency	50 Hz +/-0.05 % (crystal controlled)			
Load detection (standby)	adjustable: 1 W ... 25 W			
Operating conditions				
Ambient temperature	-20 °C ... +55 °C			
Fitting and construction				
Input current repartition, „Power Sharing“	1 A ... 30 A		1 A ... 50 A	
Degree of protection	IP 22			
Dimensions (X x Y x Z)	297 x 480 x 242 mm		297 x 494 x 242 mm	
Weight	33 kg	39 kg	41 kg	45 kg

Technical data at 25 °C / 77 °F

[areas of application]





Steca Xtender XTM

1500-12, 2000-12, 2400-24, 3500-24, 2600-48, 4000-48

The basic functions of the combined inverter of the Steca Xtender series are the inverter, the battery charger, the switching function and the support of external sources of alternating current. These functions can be combined and controlled fully automatically, the range offers outstanding user-friendliness and very good exploitation of the energy available.

All the settings of the Steca Xtender XTM can be remote controlled. When a software with new functions is available, it can be loaded into the system, so the Steca Xtender XTM always stays up to date. Several Steca Xtender XTM can be connected in parallel or to form a three-phase system. That means that up to nine Steca Xtender XTM can work together.

Multifunction contacts

These potential-free contacts can be programmed for many different applications. They can react to any event outside or inside of the inverter (grid availability, battery voltage, fault message ...) They can also be programmed on a timer or can be switched on during particular times (at night, at the weekend ...). In this way, they can serve to start up a generator, to switch off less important loads, to signal a fault, to charge batteries depending on the situation, etc.

Smart-boost function

With the smart-boost function, the output of another source of alternating current, such as a power generator or a land connection, can be increased; even when special loads are being used (inductive, asymmetric, with high switch-on current). It is also possible to combine the Steca Xtender XTM with almost all inverters which are already present in order to increase the available output.

Product features

- True sine wave voltage
- Excellent overload capabilities
- Optimal battery protection
- Adjustable integrated battery charger
- Multistage programmable battery charger with PFC
- Automatic load detection
- Standby load detection adjustable over a wide range, starting from a low value
- Parallel connectable
- Best reliability
- Can be used as a back-up system or uninterruptible power supply (UPS)
- Multifunction contact
- Adjustable power sharing
- Reliable and noiseless with any kind of load
- Support of sources of alternating current (Smart Boost)
- Automatic support for peak loads (Power Shaving)
- Ultra-fast transfer relay
- High efficiency
- Control by digital signal processor (DSP)

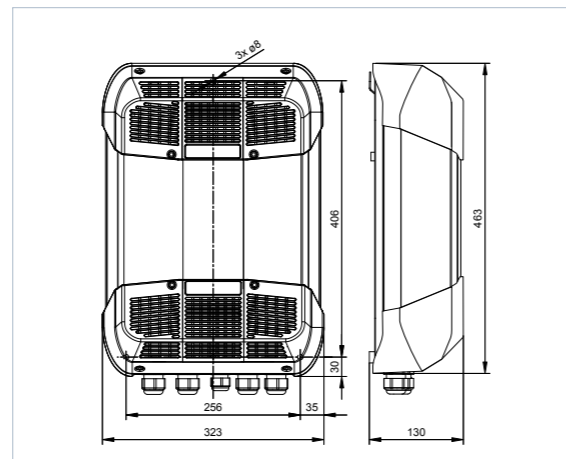

Electronic protection functions

- Deep discharge protection
- Battery overvoltage shutdown
- Overtemperature and overload protection
- Short circuit protection
- Reverse polarity protection by internal fuse
- Acoustic alarm at deep discharge or overheating

Displays

- 5 LEDs show operating states
- for operation, fault messages

Operation

- Main switch
- Adjustable load detection

Options

- Type with 115 V / 60 Hz
- Model with protective lacquered mainboard
- Temperature sensor BTS-01 to correct the voltage thresholds according to the current battery temperature

Certificates

- Compliant with European Standards (CE)
- RoHS compliant

	XTM 1500-12	XTM 2000-12	XTM 2400-24	XTM 3500-24	XTM 2600-48	XTM 4000-48
Characterisation of the operating performance						
System voltage	12 V	12 V	24 V	24 V	48 V	48 V
Continuous power	1,500 VA	2,000 VA	2,000 VA	3,000 VA	2,000 VA	3,500 VA
Power 30 min.	1,500 VA	2,000 VA	2,400 VA	3,500 VA	2,600 VA	4,000 VA
Power 5 sec.	3.4 kVA	4.8 kVA	6 kVA	9 kVA	6.5 kVA	10.5 kVA
Max. efficiency	93 %	93 %	94 %	94 %	96 %	96 %
Own consumption standby / ON	1.4 W / 8 W	1.4 W / 10 W	1.6 W / 9 W	1.6 W / 12 W	2 W / 10 W	2.1 W / 14 W
Power Factor Correction (PFC)	according EN 61000-3-2					
Acoustic level	< 40 dB / < 45 dB (without / with ventilation)					
Input side						
Input voltage	< 265 V AC (adjustable: 150 V AC ... 265 V AC)					
Charging current adjustable	0 A ... 70 A	0 A ... 100 A	0 A ... 55 A	0 A ... 90 A	0 A ... 30 A	0 A ... 50 A
Max. current on transfer system	50 A					
Input frequency	45 Hz ... 65 Hz					
Battery side						
Battery voltage	9.5 V ... 17 V	9.5 V ... 17 V	19 V ... 34 V	19 V ... 34 V	38 V ... 68 V	38 V ... 68 V
AC output side						
Output voltage	230 V AC +/- 2 % / 190 V AC ... 245 V AC (true sine wave)					
Output frequency	50 Hz, adjustable: 45 Hz ... 65 Hz +/- 0.05 % (crystal controlled)					
Total harmonic distortion	< 2 %					
Load detection (standby)	2 W ... 25 W					
Operating conditions						
Ambient temperature	-20 °C ... +55 °C					
Fitting and construction						
Power Smart-Boost	1,500 VA	2,000 VA	2,400 VA	3,500 VA	2,600 VA	4,000 VA
Input current balance adjustment	1 A ... 50 A					
Multifunction contact adjustable	2 independent contacts 16 A / 250 V AC (potential free change-over contacts)					
Degree of protection	IP 20					
Dimensions (X x Y x Z)	323 x 463 x 130 mm					
Weight	15 kg	18.5 kg	16.2 kg	21.2 kg	16.2 kg	22.9 kg
Cooling principle	fan from 55 °C					
Parallel connection possible	3 x 1 phase and three-phase					

Technical data at 25 °C / 77 °F



Steca RCC-02

Remote control and display (incl. 2 m cable)

Suitable for wall-mounting (see page 55).

Not illustrated:

Steca RCC-03

Remote control and display (incl. 2 m cable)

Suitable for rack installation.

Steca BTS-01

Battery temperature sensor (incl. 5 m cable)

This sensor allows the battery voltages to be adjusted to the battery temperature.

Communications cable

Connection to the three-phase system or to the parallel connection CAB-RJ45-2 (2 m)

This is used to connect several inverters together to a three-phase system or a system connected in parallel.

[areas of application]





Steca Xtender XTH

3000-12, 5000-24, 6000-48, 8000-48

The basic functions of the combined inverter of the Steca Xtender series are the inverter, the battery charger, the switching function and the support of external sources of alternating current. These functions can be combined and controlled fully automatically, the range offers outstanding user-friendliness and very good exploitation of the energy available.

All the settings of the Steca Xtender XTH can be remote controlled. When a software with new functions is available, it can be loaded into the system, so the Steca Xtender XTH always stays up to date. Several Steca Xtender XTH can be connected in parallel or to form a three-phase system. That means that up to nine Steca Xtender XTH can work together.

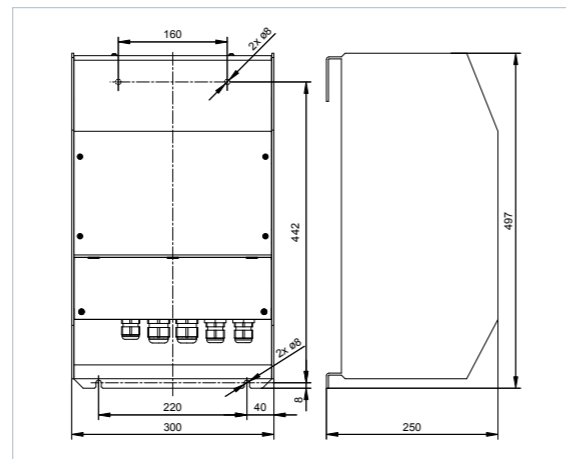

Multifunction contacts

These potential-free contacts can be programmed for many different applications. They can react to any event outside or inside of the inverter (grid availability, battery voltage, fault message ...) They can also be programmed on a timer or can be switched on during particular times (at night, at the weekend ...). In this way, they can serve to start up a generator, to switch off less important loads, to signal a fault, to charge batteries depending on the situation, etc.

Smart-boost function

With the smart-boost function, the output of another source of alternating current, such as a power generator or a land connection, can be increased; even when special loads are being used (inductive, asymmetric, with high switch-on current). It is also possible to combine the Steca Xtender XTH with almost all inverters which are already present in order to increase the available output.

Product features

- True sine wave voltage
- Excellent overload capabilities
- Optimal battery protection
- Adjustable integrated battery charger
- Multistage programmable battery charger with PFC
- Automatic load detection
- Standby load detection adjustable over a wide range, starting from a low value
- Parallel connectable
- Best reliability
- Can be used as a back-up system or uninterruptible power supply (UPS)
- Multifunction contact
- Adjustable power sharing
- Reliable and noiseless with any kind of load
- Support of sources of alternating current (Smart Boost)
- Automatic support for peak loads (Power Shaving)
- Ultra-fast transfer relay
- High efficiency
- Control by digital signal processor (DSP)

Electronic protection functions

- Deep discharge protection
- Battery overvoltage shutdown
- Overtemperature and overload protection
- Short circuit protection
- Reverse polarity protection by internal fuse (except Steca Xtender XTH 3000)
- Acoustic alarm at deep discharge or overheating

Displays

- 5 LEDs show operating states
- for operation, fault messages

Operation

- Main switch
- Adjustable load detection

Options

- Type with 115 V / 60 Hz (except Steca Xtender XTH 8000-48)
- Model with protective lacquered mainboard
- Temperature sensor BTS-01 to correct the voltage thresholds according to the current battery temperature

Certificates

- Compliant with European Standards (CE)
- RoHS compliant

	XTH 3000-12	XTH 5000-24	XTH 6000-48	XTH 8000-48
Characterisation of the operating performance				
System voltage	12 V	24 V	48 V	48 V
Continuous power	2,500 VA	4,500 VA	5,000 VA	7,000 VA
Power 30 min.	3,000 VA	5,000 VA	6,000 VA	8,000 VA
Power 5 sec.	7.5 kVA	12 kVA	15 kVA	21 kVA
Max. efficiency	93 %	94 %	96 %	96 %
Own consumption standby / ON	1.4 W / 14 W	1.8 W / 18 W	2.2 W / 22 W	2.4 W / 30 W
Power Factor Correction (PFC)	according EN 61000-3-2			
Acoustic level	< 40 dB / < 45 dB (without / with ventilation)			
Input side				
Input voltage	< 265 V AC (adjustable: 150 V AC ... 265 V AC)			
Charging current adjustable	0 A ... 160 A	0 A ... 140 A	0 A ... 100 A	0 A ... 120 A
Max. current on transfer system	50 A			
Input frequency	45 Hz ... 65 Hz			
Battery side				
Battery voltage	9.5 V ... 17 V	19 V ... 34 V	38 V ... 68 V	38 V ... 68 V
AC output side				
Output voltage	230 V AC +/- 2 % / 190 V AC ... 245 V AC (true sine wave)			
Output frequency	50 Hz, adjustable: 45 Hz ... 65 Hz +/- 0.05 % (crystal controlled)			
Total harmonic distortion	< 2 %			
Load detection (standby)	2 W ... 25 W			
Operating conditions				
Ambient temperature	-20 °C ... +55 °C			
Fitting and construction				
Power Smart-Boost	3,000 VA	5,000 VA	6,000 VA	8,000 VA
Input current balance adjustment	1 A ... 50 A			
Multifunction contact adjustable	2 independent contacts 16 A / 250 V AC (potential free change-over contacts)			
Degree of protection	IP 20			
Dimensions (X x Y x Z)	300 x 497 x 250 mm			
Weight	34 kg	40 kg	42 kg	46 kg
Cooling principle	fan from 55 °C			
Parallel connection possible	3 x 1 phase and three-phase			

Technical data at 25 °C / 77 °F



Steca RCC-02

Remote control and display (incl. 2 m cable)

Suitable for wall-mounting (see page 55).

Not illustrated:

Steca RCC-03

Remote control and display (incl. 2 m cable)

Suitable for rack installation.

Steca BTS-01

Battery temperature sensor (incl. 5 m cable)

This sensor allows the battery voltages to be adjusted to the battery temperature..

Communications cable

Connection to the three-phase system or to the parallel connection CAB-RJ45-2 (2 m)

This is used to connect several inverters together to a three-phase system or a system connected in parallel.



Steca X-Connect system

Prewired mounting structure for devices from the Steca Xtender XTH series

[areas of application]





Steca Solsum VC

Voltage converter

When appliances such as cassette recorders or radios which are designed to use dry batteries are connected to 12 V or 24 V batteries, they normally require a lower voltage than that supplied by the system battery.

These appliances can be powered using the Steca Solsum VC adjustable voltage converter. The Solsum VC is also suitable for operating a 12-V appliance with a 24-V battery. The maximum output current for doing so is 1.5 A. When developing this converter, the greatest value was placed in safety and reliability. Five programmed output voltages enable universal usage.

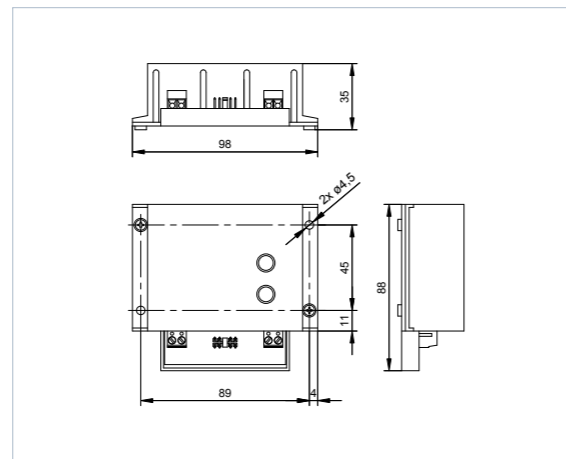

Product features

- Wide input voltage range
- Low own consumption
- Screw terminals allow universal and rapid installation

Electronic protection functions

- Overtemperature and overload protection
- Reverse polarity protection
- Short circuit protection

Displays

- 2 multi-coloured LEDs show operating states — for operation and polarity

Operation

- Configuration by jumpers

Certificates

- Compliant with European Standards (CE)
- Manufactured according to ISO 9001 and ISO 14001

	VC
Characterisation of the operating performance	
System voltage	12 V (24 V)
Own consumption	2 mA (U _e = 12 V)
DC input side	
Input voltage ¹	5 V ... 30 V
DC output side	
Output voltage	3 V; 6 V; 7.5 V; 9 V; 12 V
Output current ²	< 1,500 mA
Fitting and construction	
Terminal (fine / single wire)	1.5 mm ² / 2.5 mm ² - AWG 16 / 14
Dimensions (X x Y x Z)	98 x 88 x 35 mm
Weight	50 g

Technical data at 25 °C / 77 °F

Determining the output current					
Output current	3 V	6 V	7.5 V	9 V	12 V
Output voltage 12 V	1,000 mA	1,500 mA	1,500 mA	1,500 mA	1,500 mA ¹
System voltage 24 V	400 mA	500 mA	500 mA	600 mA	700 mA

1. The input voltage has to be at least 2 V higher than the output voltage.
2. The max. current depends on the input and output voltage.

[areas of application]



Steca MDC / MDCI

DC-DC-voltage converters

DC-DC voltage converters are used when the DC-output voltage of the PV system does not match the requirements of the appliance.

Since a voltage level of 12 V is required for most low-voltage appliances such as lamps, multimedia devices, radios or mobile phones, the various models of the voltage converters deliver a stable supply of 12 V. For instance, if a 12-V energy-saving light is operated in a 24-V or 48-V system, then a suitable DC-DC voltage converter must be inserted between the load output of the charge controller and the 12-V energy-saving light.

The Steca MDC and MDCI voltage converters are designed for use in photovoltaic systems. The models with an output voltage of 13.6 V can also be used as battery chargers for a 12-V battery in a 24-V system.

For safety reasons, the Steca MDCI series is electrically insulated to protect the user. Both the Steca MDCI and the Steca MDC series are protected against high voltage spikes at the input, thus preventing harmful voltage spikes at the input of the loads.

Product features

- High efficiency
- Automatic detection of voltage
- Wide input voltage range
- Best reliability

Electronic protection functions

- Overtemperature and overload protection
- Reverse polarity protection
- Short circuit protection

Certificates

- Compliant with European Standards (CE)

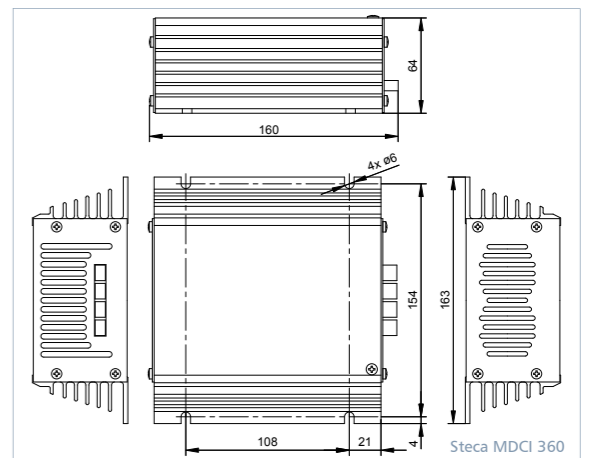
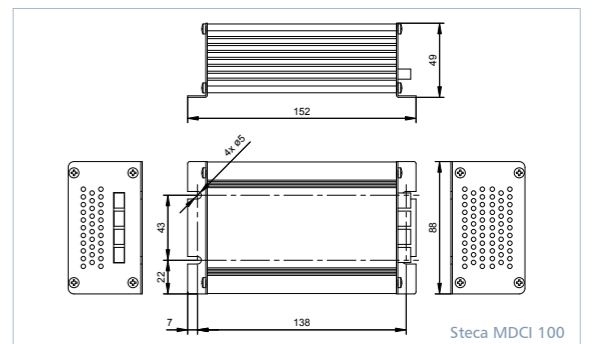

	MDC						MDCI		
	2412-5	2412-8	2412-12	2412-20	2412-30	1224-7	100	200	360
Characterisation of the operating performance									
Nominal power	65 W	105 W	160 W	275 W	415 W	170 W	100 W	200 W	360 W
Max. efficiency	90 %						85 %		
DC input side									
Input voltage	18 V ... 35 V		20 V ... 35 V			9 V ... 18 V	9 V ... 18 V / 20 V ... 35 V / 30 V ... 60 V / 60 V ... 120 V		
DC output side									
Output voltage	13,2 V			13,8 V		24 V	12,5 V / 24 V		
Output current	5.5 A	8 A	12 A	20 A	30 A	7 A	8 A / 4 A	16.5 A / 8 A	30 A / 15 A
Operating conditions									
Ambient temperature	-20 °C ... +40 °C						-20 °C ... +45 °C		
Fitting and construction									
Galvanic isolation	no						yes		
Dimensions (X x Y x Z)	87 x 55 x 49 mm	87 x 85 x 49 mm		87 x 115 x 49 mm	87 x 125 x 49 mm	87 x 115 x 49 mm	88 x 152 x 49 mm	88 x 182 x 49 mm	163 x 160 x 64 mm
Weight	170 g	250 g	260 g	480 g	600 g	300 g	500 g	600 g	1.4 kg
Cooling principle	convection				fan	convection	convection	fan	

Technical data at 25 °C / 77 °F

[areas of application]





Steca PF 166

Solar refrigerator/freezer

The Steca PF 166 is the most efficient DC energy-saving refrigerator ever to be developed. It can be used as either a refrigerator or a freezer.

The Steca PF 166 is fully programmable. The inside temperature and each of the other configuration values can be set by the user. It is therefore perfectly suited for all DC applications including even the refrigeration of medicines in hospitals. Thanks to the latest A++ energy efficiency class, together with optimal electronic control and an RPM control of the compressor, it is possible to ensure that the energy is used extremely efficiently. This leads to significant cost reductions.

This product stands out for its user-friendliness, thanks to a large digital display with setting options, the highest standards of quality and reliability and a long service life. The refrigerator or freezer is easy to clean as it has a sealing plug on the bottom for draining water. This maintenance-free appliance can work with an input voltage of either 12 V or 24 V.

Product features

- A++ energy efficiency class
- Fast cooling due to compressor speed control
- Freezer runs on a 70 W photovoltaic module in most climates
- Automatic detection of voltage
- Temperature fully programmable
- Adjustable refrigerator or freezer function
- Suitable for all DC applications
- Low maintenance and easy to clean
- Lock with two keys
- Also suitable for mobile use

Electronic protection functions

- Reverse polarity protection
- Deep discharge protection
- Power breakdown display
- Temperature alarm

Displays

- Multifunction LED display
- Digital temperature display

Operation

- Programming by buttons

Certificates

- Compliant with European Standards (CE)
- RoHS compliant
- CFC-free (R-134a)
- Developed in Germany
- Manufactured according to ISO 9001 and ISO 14001

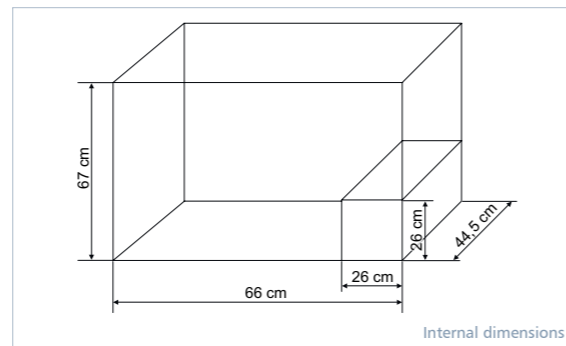

PF 166	
Certificates	
Energy efficiency class	A++
Characterisation of the operating performance	
System voltage	12 V (24 V)
Nominal power	40 W ... 100 W
Cooling volume	166 litres
Refrigerator temperature	+2 °C ... +12 °C
Freezer temperature	-20 °C ... -10 °C
DC input side	
Input voltage	10 V ... 17 V (17 V ... 31.5 V)
DC output side	
Reconnection voltage (LVR)	11.7 V (24.2 V)
Deep discharge protection (LVD)	10.4 V (22.8 V)
Operating conditions	
Ambient temperature	+10 °C ... +43 °C
Fitting and construction	
Dimensions (X x Y x Z)	917 x 872 x 709 mm
Weight	61 kg
Cooling principle	compressor
Celsius / Fahrenheit temperature display	adjustable
Display brightness	adjustable
Hanging baskets	2
Freezer trays	3
Cold battery	1
Automatic energy-saving mode	yes

Technical data at 25 °C / 77 °F

Consumption freezer					
Ambient temperature	20 °C	25 °C	30 °C	35 °C	40 °C
Interior temperature -10 °C	200 Wh / day	300 Wh / day	410 Wh / day	570 Wh / day	770 Wh / day
Interior temperature -20 °C	410 Wh / day	570 Wh / day	770 Wh / day	1,000 Wh / day	1,400 Wh / day
Consumption refrigerator					
Ambient temperature	20 °C	25 °C	30 °C	35 °C	40 °C
Interior temperature 10 °C	30 Wh / day	57 Wh / day	93 Wh / day	140 Wh / day	208 Wh / day
Interior temperature 3 °C	70 Wh / day	110 Wh / day	165 Wh / day	240 Wh / day	340 Wh / day



Steca Solsum ESL

5 W, 7 W, 11 W / 12 V energy-saving lights

The electronics of these 12 V DC energy-saving compact fluorescent lamps (CFLs) was developed by Steca and continuously improved.

Preheating, a high electronic efficiency and low thermal losses increase the service life of these CFLs to about 100,000 switch cycles. The Steca energy-saving lights feature a much higher efficiency (lm/W) than LEDs or incandescent bulbs.



Product features

- Brightness of 11 W CFL is comparable with a 60 W incandescent bulb
- Saves up to 80% of energy compared to an incandescent bulb
- Greatest switch cycle stability
- Best reliability
- Easy to install by a E27 or bayonet socket
- Compact and robust product design

Electronic protection functions

- Reverse polarity protection

Certificates

- Approved by the World Bank for China and Sri Lanka
- Compliant with European Standards (CE)
- Developed in Germany
- Manufactured according to ISO 9001 and ISO 14001

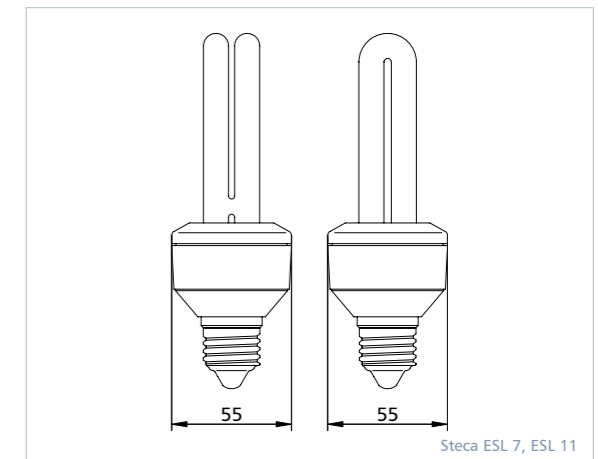

	ESL 5	ESL 7	ESL 11
Characterisation of the operating performance			
Nominal voltage	12 V		
Nominal power	5 W	7 W	11 W
Rated current	420 mA	580 mA	920 mA
Luminous flux	250 lm	370 lm	650 lm
Luminous efficiency	50 lm / W	52 lm / W	60 lm / W
Life span	> 9,000 h		
Switching cycles	100,000		
DC input side			
Input voltage	10 V ... 15 V		
Operating conditions			
Ambient temperature	-20 °C ... +50 °C		
Fitting and construction			
Dimensions (X x Y x Z)	123 x 55 mm	133 x 55 mm	163 x 55 mm
Weight	125 g		135 g
Socket	E27 / bayonet		
Light colour	cool white (6,400K) / warm white (2,700K)		

Technical data at 25 °C / 77 °F





Steca ULED 11

Energy-saving light

Steca ULED 11 is optimally suited for small applications as the 1.1 W LED has very high efficiency. Due to its solid case it is optimally suited for use under critical circumstances as it is well protected. 18 single warm white LEDs form a good and well recognized color.

Product features

- High efficiency
- Low weight
- Very long lifetime
- Simple installation
- Maintenance-free
- Low own consumption
- Best reliability

Electronic protection functions

- Reverse polarity protection

Certificates

- Compliant with European Standards (CE)
- RoHS compliant



ULED 11	
Characterisation of the operating performance	
Nominal voltage	12 V
Nominal power	1.1 W
Rated current	92 mA
Luminous flux	45 lm
Luminous efficiency	42 lm / W
Life span	> 30,000 h
DC input side	
Input voltage	10.5 V ... 14.5 V
Operating conditions	
Ambient temperature	-30 °C ... +60 °C
Fitting and construction	
Dimensions (X x Y x Z)	75 x 50 mm
Weight	70 g
Socket	E27
Light colour	warm white (3,300 K)

Technical data at 25 °C / 77 °F

Steca fuel cells

EFOY 600, 900, 1200, 1600 and EFOY Pro 600, 1200, 1600

EFOY fuel cells are a reliable alternative power supply for mobile and portable applications in the output range of up to 1,000 W. If required, they can charge batteries automatically, without any user intervention – 24 hours a day and in all weathers. Today EFOY fuel cells are established all around the world for use in leisure time pursuits. EFOY Pro is the perfect energy solution for challenging off-grid industrial applications.

Product features

EFOY Pro for industrial applications

- Automatic detection of voltage
- Low weight
- Quiet and emission-free
- Maintenance-free
- Compact and robust product design
- Easy to integrate into a Steca hybrid system
- Plug & play solution
- Liquid tank for methanol allows fuel to be managed easily
- Remote controlled via GSM modem
- Made in Germany

Fuel cell for industrial applications



EFOY Pro 600, 1200, 1600

Fuel cell for leisure time pursuits



EFOY 600, 900, 1200, 1600

Product features

EFOY for leisure time pursuits

- Low weight
- Quiet and emission-free
- Maintenance-free
- Plug & play solution
- Liquid tank for methanol allows fuel to be managed easily
- Made in Germany

	EFOY 600	EFOY 900	EFOY 1200	EFOY 1600	EFOY Pro 600	EFOY Pro 1200	EFOY Pro 1600
Characterisation of the operating performance							
Nominal voltage	12 V				12 V (24 V)		
Nominal power	25 W	38 W	50 W	65 W	25 W	50 W	65 W
Rated current	2,1 A	3,1 A	4,2 A	5,4 A	2,1 A (1,05 A)	4,2 A (2,1 A)	5,4 A (2,7 A)
Methanol consumption*	0,9 l / kWh				0,9 l / kWh		
Acoustic level (in a distance of 7 m)	23 dB [A]				23 dB [A]		
DC output side							
Charge capacity	600 Wh / day 50 Ah / day	900 Wh / day 75 Ah / day	1.200 Wh / day 100 Ah / day	1.600 Wh / day 130 Ah / day	600 Wh / day	1.200 Wh / day	1.560 Wh / day
Operating conditions							
Ambient temperature	-20 °C ... +40 °C				-20 °C ... +45 °C		
Recommended batteries	12 V lead batteries (lead acid or lead gel) with 40 to 200 Ah capacity				12 V lead batteries (lead acid or lead gel) with 40 to 200 Ah capacity		
Fitting and construction							
Dimensions (X x Y x Z)	435 x 200 x 276 mm				433 x 188 x 278 mm		
Weight	6,5 kg	6,6 kg	7,6 kg	7,9 kg	7,8 kg	8,2 kg	8,4 kg

Technical data at 25 °C / 77 °F

*Effective consumption depends on operation conditions.

Accessories for EFOY and EFOY Pro fuel cells

Steca tank cartridge



	M5	M10	M28*
Characterisation of the operating performance			
Volume	5 litres	10 litres	28 litres
Capacity	5,5 kWh	11,1 kWh	31,1 kWh
Fitting and construction			
Dimensions (X x Y x Z)	190 x 145 x 283 mm	230 x 193 x 318 mm	420 x 280 x 360 mm
Weight	4,3 kg	8,4 kg	22 kg

Technical data at 25 °C / 77 °F

**Requires the M28 adapter (optional, only available for Efoy Pro)

[areas of application]



[areas of application]





Accessories for Steca Tarom and Steca Power Tarom

Steca PA Tarcom

Data logger

The Steca PA Tarcom data logger is connected to the RJ45 interface of the Steca Tarom or Power Tarom charge controller, or via the Steca PA HS200.

The data logger is available in several different versions: as a simple RS232 interface to directly save and read data on the PC or Laptop (Steca PA Tarcom 01), as a data logger with an integrated analogue modem (Steca PA Tarcom RM), as a data logger with an optional telephone connection (Steca PA Tarcom RMT) and as a data logger with an integrated GSM modem for remote monitoring (Steca PA Tarcom GSM). The Steca PA Tarcom is delivered with its accompanying software.

Product features

- 4 years maximum storage capacity (1 Mbyte)
- Adjustable logging intervals
- Stores 8 data sets at programmed intervals
- Freely programmable alarm states

Displays

- LED shows operating states

Interfaces

- Two RJ45 cable sockets
- RS232 serial interface
- Analogue sensor input e.g. for radiation or wind speed
- Alarm contact

Tarcom software

- Internet services for worldwide access
- Downloads data from the logger to a PC
- List of data sets can be exported to MS-EXCEL
- Graphic visualisation of data sets (values/time)
- Analyzes energy flows (Ah) within a PV hybrid system
- Activation and selection of alarm types
- Configurates modem
- Sets telephone number to call
- Tells the data logger at what time it has to call

Certificates

- Compliant with European Standards (CE)
- Made in Germany
- Developed in Germany

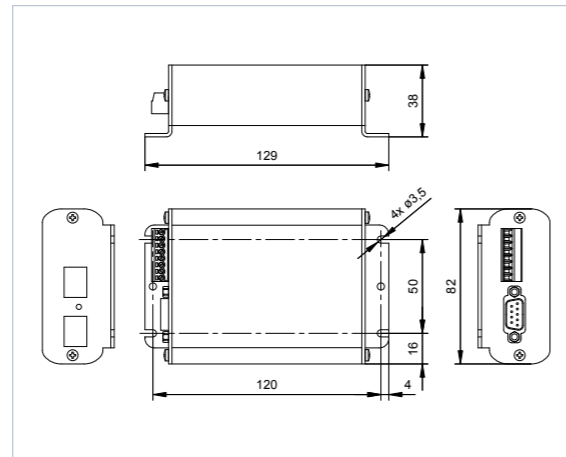

	01	RM / RMT	GSM	Ethernet
Characterisation of the operating performance				
System voltage	12 V / 24 V / 48 V			
Logger capacity	1 Mbit = 2 min. (11 days) → 4 h (4 years)			
Own consumption	< 10 mA	30 mA		
Recorded values	relative time, total charge current, battery current, solar module current, load current, SOC, battery voltage, system status, analog sensor			
System status information	night, overload, load disconnect, overvoltage, low voltage, over temperature, no module			
DC output side				
Battery voltage	8 V ... 65 V			
Safety				
Alarm output	for all recorded parameters programmable			
Fitting and construction				
Interfaces	RS232	analog modem	gsm modem	ethernet
Configurable analog auxiliary input	0 mV ... 150 mV			
Dimensions (X x Y x Z)	129 x 82 x 38 mm			
Weight	150 g			

Technical data at 25 °C / 77 °F

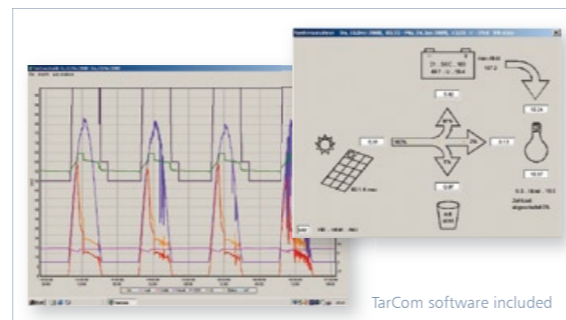

TarCom software included

[areas of application]



Accessories for Steca Tarom and Steca Power Tarom

Steca PA HS200

Shunt

The Steca PA HS200 is a highly intelligent current sensor with extremely low own consumption.

The Steca PA HS200 comes into play when (e.g.) an inverter is directly connected to the battery and the Steca Tarom or Power Tarom charge controller cannot measure the current consumption. A shunt is also required when an additional generator (e.g. PV, wind or diesel) directly charges the battery without being connected to a Steca Tarom charge controller. The current is measured contact-free via a Hall-effect sensor. The data is transmitted to the charge controller over a cable connection. Up to two Steca PA HS200 shunts can be connected and the measured currents can be selectively added to the charging current, battery current or load current as desired.

Product features

- Automatic detection of voltage
- Wide current measuring range
- Potential free current measurement
- Communicates and stores data in the Steca PA Tarcom
- Integrated Hall sensor

Displays

- LED shows operating states
- Messages via Steca Tarom LCD display

Interfaces

- Two RJ45 cable sockets

Modes of operation

- „Battery“: measures currents which flow through the battery cable
- „Load“: measures currents of external loads not connected to the charge controller
- „Charge“: measures currents of back-up generators

Certificates

- Compliant with European Standards (CE)
- Made in Germany
- Developed in Germany

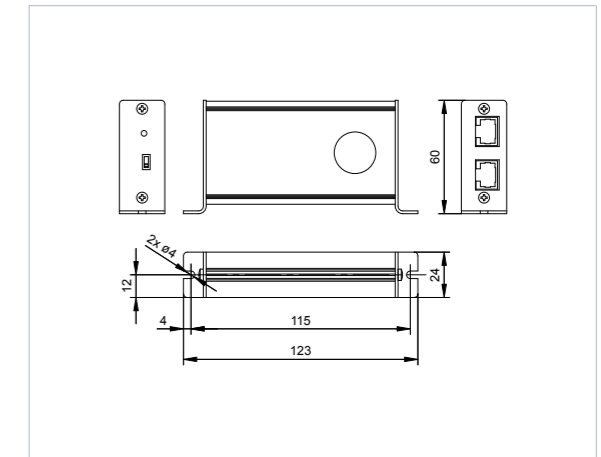
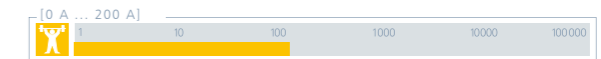

	PA HS200
Characterisation of the operating performance	
System voltage	10 V ... 65 V
Own consumption	< 9 mA
Measurement accuracy	(-20 A ... +20 A) +/-1 % (-200 A ... +200 A) +/-3 %
Operating conditions	
Ambient temperature	-15 °C ... +50 °C
Relative humidity	75 %
Fitting and construction	
Current range "battery" mode	-200 A ... +200 A
Current range "charge" mode	0 A ... +200 A
Current range "load" mode	-200 A ... 0 A
Degree of protection	IP 22
Dimensions (X x Y x Z)	100 x 60 x 25 mm
Weight	120 g
Max. diameter for battery cable	19 mm

Technical data at 25 °C / 77 °F

[areas of application]



Accessories for Steca Tarom and Steca Power Tarom

Steca PA 15

Remote control

The Steca Tarom and Power Tarom charge controllers send out signals (125 kHz on 300 Baud) which are modulated on the DC cable and received by the Steca PA 15 remote control.

These signals contain information on the batteries' state of charge (SOC). The Steca PA 15 features five different operating modes (see below) which can be set using five different jumper positions. The maximum switching capacity of 15 A can be increased with a Steca PA EV200 DC relay to up to 200 A if desired.



Product features

- Receives information on SOC and time (day/night)
- Load control via priority assignment
- Adjustable SOC thresholds
- Connects a maximum of 9 solar arrays in parallel
- Current surge switch function

Electronic protection functions

- Switches off load if there is no signal
- Reverse polarity protection by internal fuse
- Overtemperature and overload protection

Operation

- Configuration by jumpers

Modes of operation

- Management of parallel solar generators
- When the battery is full, excess energy is redirected to additional loads such as pumps, water heaters
- Automatic start / stop of diesel or wind back-up generators
- Night light function
- Acoustic alarm at deep discharge or overheating

Certificates

- Compliant with European Standards (CE)
- Made in Germany
- Developed in Germany
- Manufactured according to ISO 9001 and ISO 14001

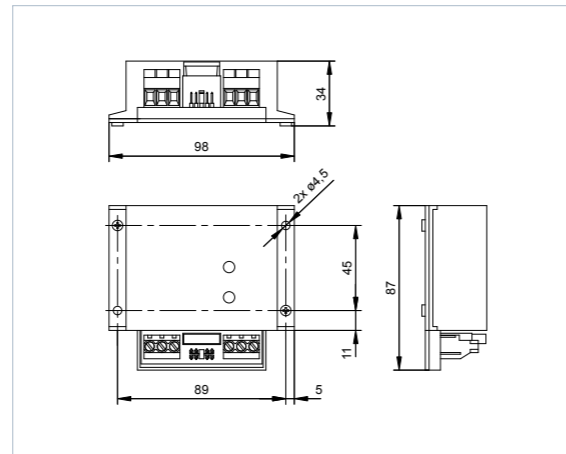

PA 15	
Characterisation of the operating performance	
Power supply	10.5 V ... 60 V DC, 5 mA
Data transmission	300 Baud
Transmission frequency	125 kHz signal frequency, 450 kHz intermediate frequency
DC output side	
Load current	15 A; 10 A at 40°C; 100 A pulse < 10 µs
Safety	
Overload protection	by 15 A fuse
Wrong polarity protection	fuse
Operating conditions	
Ambient temperature	-10 °C ... +50 °C
Fitting and construction	
Terminal (fine / single wire)	2.5 mm ² / 4 mm ² - AWG 14 / 12
Degree of protection	IP 22
Dimensions (X x Y x Z)	98 x 87 x 34 mm
Weight	110 g

Technical data at 25 °C / 77 °F

Steca PA EV200 DC

12 V / 24 V, 36 V / 48 V DC relay

The Steca PA EV200 relay increases the switching capacity of the Steca PA 15 remote control from 15 A to 200 A (up to 10 kW). The relay is connected to the Steca PA 15 remote control at the load output and, for example, interrupts the battery voltage to a back-up generator when the end-of-charge voltage is reached. The relay is hermetically sealed and operates safely in difficult environmental conditions such as dust, salt and moisture.



Product features

- Low own consumption
- Ready for connection to the Steca PA 15 remote control



	Typ A	Typ B
Characterisation of the operating performance		
System voltage	12 V (24 V)	36 V (48 V)
Coil voltage	9 V ... 36 V	32 V ... 95 V
Rated current	200 A	200 A
Life span	1 million switching cycles	
Contact resistance	0.1 mΩ ... 0.3 mΩ	
Operating conditions		
Ambient temperature	-40 °C ... +85 °C	
Fitting and construction		
Dimensions (X x Y x Z)	63 x 80 x 72 mm	
Weight	430 g	

Technical data at 25 °C / 77 °F

[areas of application]



[areas of application]



Steca PA RC100

Remote control

Steca PA RC100 remote control allows to program Steca solar charge controllers. The values can be adjusted with the help of switches. After a restart of the charge controller the new settings can be activated by pressing the program-button on the Steca PA RC100. An LED will transfer the values to the controller.

Product features

- Low weight
- Simple installation
- Maintenance-free
- Low own consumption
- Best reliability



PA RC100	
Characterisation of the operating performance	
Supply voltage	4.5 V (3 * 1.5 V AAA / R03 batteries)
Adjustable parameters	- Type of battery: gel / liquid - Night-light function - End of charge voltages (float / boost / equal) - Deep discharge protection (LVD) - LVD factor - Switch-on threshold
Suitable for the following Steca charge controllers	- Steca Solsum F - Steca PPS - Steca Solarix MPPT 2010
Fitting and construction	
Dimensions (X x Y x Z)	115 x 57 x 20 mm
Weight	90 g

Technical data at 25 °C / 77 °F

[areas of application]



Steca PA IRS 1008/180

Motion detector

The Steca PA IRS 1008/180 motion detector is connected to the load output of the night light charge controller. This supplies power to the light, which is then turned on for a few minutes when some movement is detected.

The Steca PA IRS 1008/180 stands out, above all, with its extremely low own consumption, and is therefore optimal for use in solar power systems.



PA IRS 1008/180	
Characterisation of the operating performance	
Own consumption	6 mA
Turn on time	1 min. ... 5 min.
DC output side	
Battery voltage	12 V
Load current	5 A
Fitting and construction	
Reach / detection area	7 m / 180°
Degree of protection	IP 65

Technical data at 25 °C / 77 °F

[areas of application]



Accessories for Steca Xtender XTH

Steca RCC-02

Remote control and display

Lots of information on the status of the system can be retrieved using the graphic display of the Steca RCC-02. Any incidents within the system are also saved and displayed. This means that any problems which might occur are identified early.

Many values of the Steca Xtender can be set using the Steca RCC-02, such as the charging process of the battery charger, the programming of the multifunctional contacts and the various operating modes.

An SD-card slot can be used to save parameters, for transferring data or updating the software.



RCC-02	
Fitting and construction	
Degree of protection	IP 20
Dimensions (X x Y x Z)	170 x 170 x 46 mm
Weight	400 g

Technical data at 25 °C / 77 °F

Displays

- Multifunction graphical LCD display with backlighting

Operation

- Programming by buttons

Certificates

- Compliant with European Standards (CE)
- RoHS compliant

[areas of application]



Accessories for Steca Solarix PI

Steca PAx4

Parallel switch box

Up to four Steca Solarix PI can be operated in parallel. The connections are made via an external box, the Steca PAx4.

A further innovation that has gone into the Steca Solarix PI is the communication with the solar charge controllers from the Steca Tarom and Power Tarom series. A data connection to the charge controller can be created via the Steca PAx4.



PAx4	
Operating conditions	
Ambient temperature	-20 °C ... +45 °C
Relative humidity	0 % ... 95 %
Fitting and construction	
Cable	data cable master: 0.5 m red data cable slave 1: 0.5 m grey data cable slave 2: 1 m grey data cable slave 3: 1 m grey data cable Steca Tarom: 3 m black
Interfaces	6 x RJ45 (4 x inverter, 2 x Steca Tarom)
Degree of protection	IP 20
Dimensions (X x Y x Z)	206 x 117 x 64 mm
Weight	800 g

Technical data at 25 °C / 77 °F



"From the assembly of the components to the finished device – from the development to the after-sales service."

Environmental protection in series

We are thinking of tomorrow

For Steca, there are many aspects to environmental and climate protection and the resultant reduction in CO₂ and environmental poisons.

With Steca charging technology, the devices in battery charging systems use the maximum energy storage potential and treat damaged or totally discharged batteries. Complete management systems for bus maintenance facilities help prevent environmental pollution by reducing cold-run phases.

In addition to the obvious need to apply environmentally-friendly processes, electronic products from Steca contribute both to reducing energy consumption and environmental pollution around the world, as well as to spreading the use of regenerative energy sources by means of solar technology.

Not without reason is Steca listed as an authority for energy generation in the German federal government's environmental technology atlas "Green Tech made in Germany". Products in the area of solar electronics facilitate environmentally-friendly use of clean and free solar energy. Today, in the photovoltaic and solar thermal energy sectors, over 1.5 million controllers manage and control solar energy systems around the world.

The company contributes to energy savings with the millions of electronic components it produces for devices classified in energy efficiency class A⁺, such as motion detectors or network circuit breakers. Devices for water and weather measuring technology facilitate further research into our environment. Electronics utilised in the fields of medicine and industry regulate analysis and production processes and thereby save energy and materials. Further examples include photovoltaic controllers for improving the energy balance in automobile applications. All battery-operated devices are developed for minimum electricity consumption with maximum output.

Steca environmental policy is based on sustainability and environmental compatibility, with a view to providing services and producing products for an ecological future. The company takes account of the whole value-added chain and involves suppliers and customers. Steca is certified in accordance with ISO 14001:2004 and organised in accordance with the EU Environmental Management and Audit Scheme.



StecaGrid 300 and StecaGrid 500

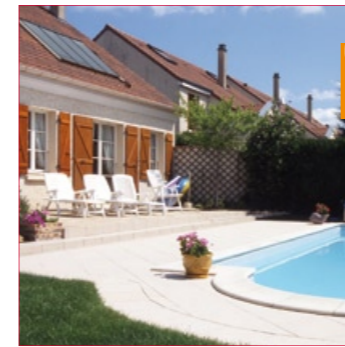

Solar controllers

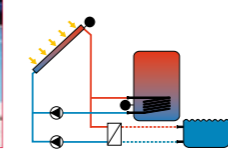

StecaGrid 2010+



Heating and domestic hot water controllers

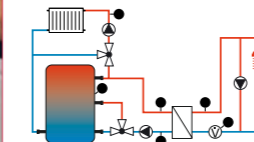

StecaGrid 10 000 3ph



System controllers

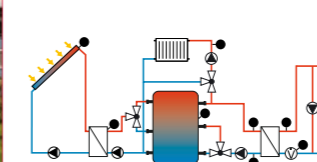



Mobile Use



Stationary Use



Equipment





PV Off Grid



Solar home system
This device is particularly suitable for solar home systems.



LCD display
This device has a digital display which allows different system information to be shown.



Inverter system
This device is suitable for applications of higher performance classes or for supplying entire villages.



Camping
This device is particularly suitable for use in mobile homes or for camping applications.



Hybrid system
Suitable for hybrid systems in which additional generators are used.



Energy efficiency class
This device is highly energy efficient – highest qualification A++



Night light function
This device is suitable for night light systems.



Uninterruptible power supply
This device can also charge the battery from an external AC source.



SOC
This device calculates the state of charge of the battery using the AtonIC processor.



Telecom
This device is specially suitable for all kinds of telecommunication applications.



Remote monitoring
This device can transfer data using wires, telephone cables or wirelessly.



Sea water
This device is particularly protected against moisture and corrosion.



Prepayment
This device is suitable for prepayment applications for bringing electricity to rural areas.



Solar module performance
Maximum input power of the connected solar modules.

Symbols

Exclusion of liability

Steca Elektronik GmbH reserves the right to supplement and change the product range offered in the catalogue, or to remove products from the range. Please contact Steca if you require additional or more up-to-date product information. The information in this catalogue is not exhaustive. We compiled this information with care. In spite of this, it may not have been updated or may no longer be applicable in individual cases. We accept no liability for imprecise or missing information in this catalogue.

Copyright Steca Elektronik GmbH ("Steca"). Steca is a protected trademark of Steca Elektronik GmbH. This trademark may only be used by third parties with our express prior permission. The sole owner of the rights to the images and logos and texts is Steca. Steca allows the free use of product pictures and graphics in the context of the presentation of its own products, as long as neither product pictures nor graphics are altered or edited, in particular with regard to cropping, modification, distortion or other deformations. The permission of Steca must always be gained for any other commercial use. "Steca Elektronik GmbH" must always be indicated as the source of the images. In return for the provision of the pictures free of charge, Steca requests a sample copy when they are used in print media, and a brief notification when they are used in film and electronic media. You agree that this agreement does not require a signature in order to become valid. The pertinent laws of the Federal Republic of Germany apply for the use of this catalogue by third parties and the use of the corresponding terms and conditions.

Images from Steca, www.burger-fotodesign.de, www.photocase.com and www.marx-studios.de and www.fotolia.com.



steca
www.steca.com

steca
www.steca.com



„Steca PV Off Grid – Power from the sun
for rural electrification.“



Steca Elektronik GmbH
Mammostraße 1
87700 Memmingen
Germany
Fon +49 (0) 8331 8558-0
Fax +49 (0) 8331 8558-132