



Installation and Operation Instruction Manual

System Manager for Photovoltaic systemes

Power Tarcom

Tarom 2070, Tarom 2140, Tarom 4055, Tarom 4110, Tarom 4140



- 1 SAFETY INSTRUCTIONS AND WAIVER OF LIABILITY 3**
 - 1.1 SYMBOL OF SAFETY INSTRUCTIONS 3
 - 1.2 HOW TO USE THIS MANUAL 3
 - 1.3 GENERAL SAFETY INSTRUCTIONS 3
 - 1.4 WAIVER OF LIABILITY 4
- 2 QUICK INSTALLATION INSTRUCTIONS 4**
- 3 APPLICATION RANGE..... 5**
 - 3.1 POWER RANGE 5
 - 3.2 OPTIONS..... 5
- 4 FUNCTIONING 7**
 - 4.1 GENERAL DESCRIPTION 7
 - 4.2 DETAILED DESCRIPTION 8
- 5 INDICATION OF STATUS..... 10**
 - 5.1 LC-DISPLAY 10
 - 5.2 ALARM CONTACT..... 11
- 6 OPERATING THE SYSTEM-MANAGER..... 11**
 - 6.1 FACTORY PRE-SET CONFIGURATIONS 11
 - 6.2 MAIN MENU..... 12
 - 6.3 MENU MANU..... 12
 - 6.4 MENU LOGG..... 13
 - 6.5 MENU CONF 13
 - 6.6 MENU PROG 14
 - 6.7 EXAMPLE OF CONFIGURATION 16
 - 6.8 EXAMPLE OF PROGRAMMING 16
- 7 INSTALLATION 17**
 - 7.1 PRECAUTIONS 17
 - 7.2 LOCATION OF INSTALLATION 17
 - 7.3 PREPARATIONS..... 18
 - 7.4 INSTALLATION AND OPERATION 19
 - 7.5 UNINSTALLING..... 20
 - 7.6 SAFETY MEASURES..... 20
- 8 OVERVOLTAGE PROTECTION IN YOUR PHOTOVOLTAIC SYSTEM 20**
- 9 GROUNDING..... 22**
 - 9.1 POSITIVE GROUNDING 22
 - 9.2 NEGATIVE GROUNDING 22
- 10 HINTS FOR THE USAGE OF MULTIPLE POWERTAROMS 23**
- 11 MAINTENANCE..... 24**
- 12 TECHNICAL DATA..... 24**
 - 12.1 PERFORMANCE DATA..... 24
 - 12.2 REGULATION DATA 24
- 13 MALFUNCTIONS AND ERRORS 25**
- 14 LEGAL GUARANTEE..... 26**
- 15 ACCESSORIES 26**

1 Safety Instructions And Waiver of Liability

1.1 Symbol of Safety Instructions



Safety instructions for personal protection and instructions that refer to the safety functions of the system are marked with this sign and are printed in bold letters.

For safe installation of other components which are not mentioned in the PV System-Manager instructions, please see the corresponding safety manual of the component manufacturer.

1.2 How To Use This Manual

This manual describes the functions and installation of a PV System-Manager - a solar charge/load controller in a PV system with a battery as storage.

For safe installation of other components, e.g. solar modules, electrical accessories and battery, please see the corresponding manual of the manufacturer.

Hint: Before you start your work, read the instructions for Installation (chapter 7; page 17). Make sure that all preparatory measures are taken.

Only start to install the System-Manager when you are sure that you have understood all the technical details of this manual. Please make sure that all steps are done in the sequence that is described in this manual.

These instructions must be handed out to all persons that work with this system. These instructions are part of the System-Manager and must be handed over in case the System-Manager is sold.

This manual has to be made accessible for any third party or parties working on the PV system.

Before you start work:

- Read the chapter Installation (chapter 7; page 17)
- Make sure that all Precautions (chapter 7.1; page 17) are taken.
- Only start to install your System-Manager when you are sure that you have understood all instructions.
- Only proceed in the order started in this manual!

1.3 General Safety Instructions

For your own safety, please note the following for installation:

Avoid generating sparks!

Solar modules produce current whenever light strikes them. Even at a small light level, the full voltage can be present. Therefore, work carefully and pay attention to the corresponding safety precautions. Disconnect the modules with separate circuit breakers while connecting the system.

During installation and wiring of the photovoltaic system, the system voltage may double (with the 12 V system up to 24 V, with the 24 V system up to 48 V, and within the 48 V system up to 96 V)



Never touch bare wire ends even in DC Systems! This habit can cause injury or even death!

Only use well insulated tools!

Do not use technical tools that are defective or broken!

The safety features of the System-Manager can be defeated when it is operated in a way not specified by the manufacturer.

Restriction of ventilation can lead to overheating of the System-Manager and thus failure. Do not cover any ventilating slots or cooling ribs.

The System-Manager must not be installed and used in moist damp areas (e. g. bathrooms) or in rooms in which there are flammable gas mixtures (from gas bottles, paint, solvents etc.)!

Do not allow anyone to store any of the above-mentioned hazardous items, or similar items in rooms where the System-Manager is installed!

The pre-set signs and marks must not be changed, removed, or made illegible.

All operations must be conducted in accordance with your national electricity regulations and local rules!

For installation in your country, please see your corresponding institutions for information on regulations and safety measures.

 **Keep children away from any and all electronics! Fatal accidents can occur!**

1.4 Waiver Of Liability

The manufacturer (STECA and its assigned representatives) cannot check that this manual is strictly followed, nor the conditions and methods for installation, operation, use and maintenance of the System-Manager.

Improper installation can lead to physical damage to the System-Manager and its safety features, and thus can endanger persons.

Therefore, we the manufacturer do not take any liability and responsibility for losses, damages and costs which are due to an improper installation, operation, use and maintenance or any other consequences resulting from such damage.

Furthermore, we do not take any liability for infringements of patent rights, or rights of third persons, which result from the use of this System-Manager.

The manufacturer reserves the right to make alterations, without prior notice, to the product itself, technical data or the installation and instruction manual.

If other components, which are not prescribed by manufacturer are connected to this System-Manager, the user has to accept the consequences.

2 Quick installation instructions

Please do all steps following the numbers below. Do not go ahead if any step failed.

1. Check system parameters and PowerTarom label : System voltage, max. module/load current
2. The solar modules have to be equipped with an extra switch or circuit breaker (CB).
3. fix the PowerTarom vertically at the wall
4. Switch off battery, modules and load:
 - a. switch off external battery fuse or CB and the main CB inside the PowerTarom
 - b. switch off the modules at the external module CB
 - c. switch off all loads
5. cabling (not yet to be switched on)
 - a. connect the battery poles to the A+ and A (blue) terminals. Respect polarity!
 - b. connect the modules to the M+ and M (blue) terminals. Respect polarity!
 - c. connect the load to the L+ and L (blue) terminals. Respect polarity!
6. switch on battery
 - a. switch on battery CB (external and in the PowerTarom). Do not switch on the modules yet.
 - b. watch the LC-display for proper indication of system voltage
7. switch on the modules
 - a. switch on the external module CB
 - b. watch the LC-display for proper indication: during daylight you should see the module currents, "I mod" and "I in"
8. switch on the load
 - a. switch on the load and check whether the load is working
 - b. watch the LC-display for proper indication of the load current (top-rightmost number).
9. installation is completed, congratulations. Check these chapters, too:
 - a. over voltage protection, part 8.

- b. multiple controllers working together, part 10 if more than one controller charge the same battery .

trouble shooting

ad 6.) LC-Display not working: battery fuse ok? cabling ok? polarity ok? check battery voltage at A+ and A-terminal ? display plug loose? Press the three left buttons ▲ ▼ ok simultaneously to restart the display.

ad 7) no module current: polarity ok? module connection ok (parallel/serial)? check module voltage outside the PowerTaron? solar radiation high enough?

ad 8.) load not working: “deep protection” active ? polarity ok? load fuses ok?

If you do not have external module switches you have to connect the battery first and then the module input to support the automatic voltage identification in 12/24V systems.

3 Application range

The system controller can be used in PV energy supplies with battery storage within the field of business and commerce as well as in firms and telecommunication devices.

Although the case is IP65 waterproofed it should be protected against heavy rain or direct sun. In order to keep the voltage drop between controller and battery to a minimum please use only short battery cables.

To adapt the final charge voltage of the battery for optimal charging the attached temperature sensor should be mounted next to the battery clamps.

The controller should only be used for regulating solar modules. It regulates the charging current from the modules using the shunt (short circuit) principle. However, the battery can also be charged by multiple PowerTaroms or other sources with appropriate battery charge functions.

3.1 Power range

The controller can be used in a wide range of performance and temperature. It automatically registers the maximum permissible temperature and disconnect the loads in the case it is exceeded. Now the complete radiating surface of the heat sink could be used for the power loss produced during charging.

Select dimensioning in a way that the ambient temperature line is not exceeded in the case of maximal charge and discharge currents. With an ambient temperature of 20 °C and correct installation the controller can process both module and load nominal currents (see labels). These nominal currents correspond to 100 % in the diagram.

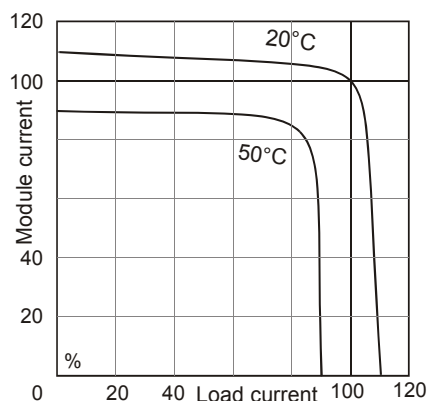

3.2 Options

The System-Manager can be operated with the following additional devices which you can purchase at authorized dealers. The options of description and instructions are pointed out by following listed possibilities and examples of use:

⇒ External current sensors can be installed in the power wires of generators or loads that are not being controlled by the System-Manager directly. This enables the System-Manager to calculate the state of charge (SOC) even when external sources like wind or diesel generators charge the battery, or when bigger loads like inverters are connected directly to the battery. The shunts register the current and send the current readings into the System-Manager digitally.

- The pair-shunt solution enables separate measurement and indication of charging and discharging currents. All load and charging currents have to be conducted across either the charge or

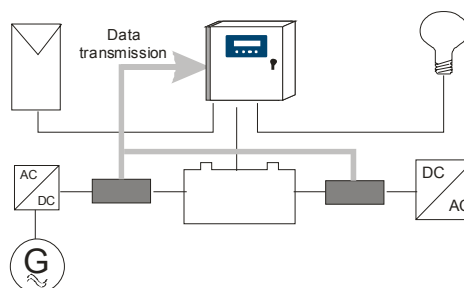



discharge current measuring shunt, except for those currents already flowing through the System-Manager (the System-Manager already measures these currents internally automatically). Please take care, that in this case all additional power sources must have a voltage limitation to prevent the battery from being overcharged.

- A single shunt can be put into the battery cable that measures the balance between the charging and discharging currents. This battery current is then displayed. With this variation, it is also possible calculate the SOC, but only one single shunt is necessary.

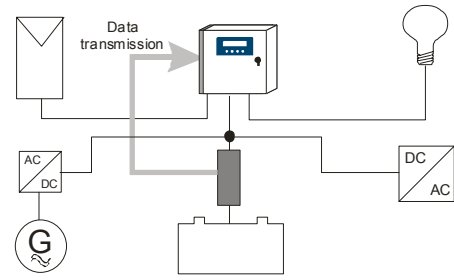

⇒ The included external temperature sensor must be used to tell the PowerTarom the actual battery temperature. The final charge voltage will then be optimized by a temperature compensation.

⇒ The System-Manager transmits system parameters via the DC power lines. These parameters can be evaluated at each point of the DC grid with additional receivers. Using this unique feature, there are many possibilities such as:

- remote load disconnection with different priorities. Remote control switches are individually programmed in accordance with the load status at which the corresponding load is switch on or off. With this feature, the light in a certain room can be switched off when the System-Manager signals that the battery is reaching a deep discharge level. However, emergency lights could be left on (no total darkness!) until a certain even lower battery level is reached. The emergency light might consume much less energy, so that it can be kept for a long period of time.
- Operating lights during nighttime, e.g. entrance lights. With the help of the module current, the System-Manager knows the intensity of light outside, so that no additional light sensor is needed.
- PV Array bank switching: With the remote control switch, additional solar modules for charging the battery can also be used without parallel operation of System-Managers. As soon as the charge current of the main solar array (connected directly to the System-Manager) is reduced to a minimum, the second array will be disconnected from the battery by the receiver. (see diagram at right) In this way, the first array supplies maximum charge current, (which is necessary to keep up the final charge voltage) and the battery can be charged according to the desired IE charge characteristic by simply switching on or off further arrays.
- operation of additional charging sources, e.g. diesel generators, grid-operated charge devices. These devices are put into operation at a low state of charge and switched off after recharging the battery. For most back-up generators, the remote control switch serves not as a power switch, but as a start signal to start the generator (only usable for 2-wire generators).
- Switching on excess loads: When the final end-of-charge voltage, is reached, the System-Manager must limit the charge current. During this time, a big portion of the solar energy is no longer used for charging the battery, and is simply wasted. However, a diversion load can be switched in by the remote control switch. As soon as there is excess current, instead of being wasted, it is forwarded to excess load such as heating coils or electrolyser units to generate hydrogen for fuel.

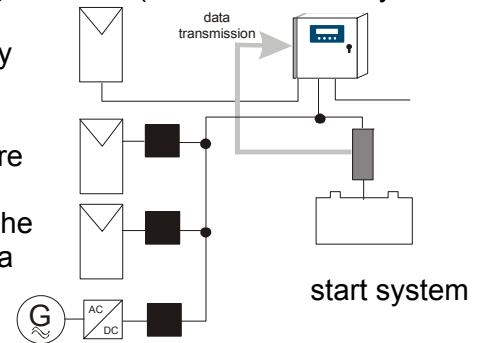
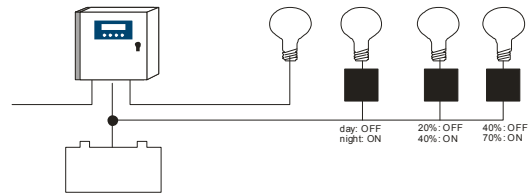

⇒ An external data logger can be connected to the System-Manager. It stores essential system parameters that can be forwarded to a PC via a serial interface (optional USB). The Data collection frequency can be chosen freely to determine the data collection period. An additional analogue input can register external parameters, that cannot be measured by the System-Manager itself: wind speed, module temperature, solar radiation, etc. The logger comes with the necessary software to operate all the above features.

- The logger is able to be programmed by the PC
- The logger is available with

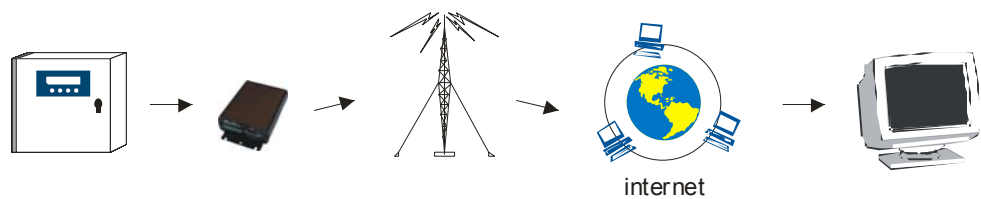

- an integrated cable modem for remote monitoring
- Instead of a cable modem you could order a GSM modem as well. With this modem you are complete independent to any infrastructure
- The TarCom version ETN can be integrated into an Ethernet computer network.

4 Functioning

The System-Manager monitors the charge status of the battery, regulates the charge process as well as it switches the loads on -off in order to make full use of the battery and to extend its life.

On delivery, the system is set for use with lead accumulators (batteries) with liquid electrolyte and can be set for accumulators with fixed electrolyte like gel batteries. The System-Manager can be used for all types of solar modules.

4.1 General Description

The System-Manager is an intelligent System-Manager in which a microprocessor has been employed for all regulating, controlling and indicating functions. The main power switching components consist of low-loss MOSFET type-transistors that have a long operating life and guarantee high performance due to their excellent conductivity, thus leading to a low degree of internal heat generation in the System-Manager.

The customer can configure all parameters without opening the System-Manager or adjusting the electronic components. Due to the unique feature of the System-Manager to send and receive data transmission via the power cable itself, a minimum number of extra sensor and data cables is required. The System-Manager is therefore easy to install even for a person without technical education, and errors caused by defective cables or sensor wires are greatly reduced.

The overcharge protection is accomplished by a pulse-width modulation parallel (shunting type) controller which is equipped with a MOSFET switch element and with a reverse diode in order to prevent current flowing back from the battery to the module at night. While following the standard IE curve, the charging process is also adjusted according to the temperature. Moreover, the history of the battery's depth of cycling over the last few days itself also determines a temporary limitation on excess final charge voltage and also limits the time of boost of equalizing charges. Voltage drops of the battery cabling and connections and due to the internal resistance of the battery itself are compensated automatically in the sophisticated patented software inside the System-Manager, without using extra sensor cables.

In order to protect the battery from being totally discharged, the loads are automatically disconnected from the battery under certain conditions. The System-Manager's microprocessor determines the remaining capacity at which no more consumption is possible without damaging the battery and shuts off the loads if the remaining capacity in the battery falls below this limit. Furthermore, the loads are switched off in the case of excess current or temperature for the protection of the System-Manager, and in the case of excess voltage for the protection of the loads, and in the case of low voltage for the protection of the battery.

The integrated temperature compensated equalisation charge function automatically does preventive maintenance on the battery from time to time via electrolyte circulation (controlled gassing) and increases battery life by preventing harmful acid or sulphate layers. This increase in the final charge voltage is time-triggered after the battery has reached a certain level of voltage in normal charging. After this equalisation charge time is completed, the System-Manager returns to normal charging. In addition, equalisation charging enables a faster full charging during bad weather periods e.g., in winter, as only part of the energy is need for gassing, whereas the remaining energy can be used for fast charging. This timed equalisation charge function is activated by either undershooting of a determined SOC, or by exceeding a certain period of time after the last equalisation charge. Equalisation charging can also be activated manually.

An LCD display indicates important information on the current operating status. The first line informs briefly on the most important basic parameters and the second line displays fine parameters or system information. This displays are changing their information every three seconds.

The System-Manager has a reverse battery protection and is secure against no-load operation and short circuit. The load output is protected against over-current. However, it is very likely that the System-Manager is damaged if components are not connected to the correct terminals (e.g. if battery is connected in reverse polarity to the module input terminals).

4.2 Detailed Description

4.2.1 SOC (State Of Charge) Calculation

With the help of a proprietary patented software algorithm, the System-Manager is capable to "learn" the characteristics and parameters of the battery. This SOC reading is very accurate and therefore is the basis for most controlling and monitoring functions. However, if system components are directly connected to the battery, the state of charge can only be determined with the help of the optional current sensors HS200. The state of charge always refers to the actual capacity which the battery has in accordance to its age. So a SOC of 50 % does not mean that half of the battery's nominal rated capacity can be used, but that only half of the battery's REAL MEASURED capacity is remaining.

The state of charge is not dependant on the battery voltage, but on the amount of energy taken out. Traditional controllers usually determine a final load voltage that hardly ever corresponds to the discharge depth. During discharge, nominal acid density is being reduced and sulphates are placed on the battery plates. If discharge is too deep, this growth leads to harmful sulphatation that reduces the battery's capacity considerably, thus making the battery useless for energy storage. The traditional measuring procedures (Ah balancing, acid density measuring) are time-consuming and cost intensive and are seldom integrated in charge controllers.

If generators or loads are directly connected to the battery without current sensor HS200, the SOC gets "tricked" and its determination is wrong. However, despite erroneously measured SOC values., the System-Manager still prevents the battery from falling below certain voltage values, in order to protect the battery from a too-deep damaging discharge

The System-Manager is able to convert to a voltage regulation mode (chapter 6.5, page 13). Now System-Manager will operate like a conventional charge controller. We recommend this conversion when using additional generators (diesel, wind, etc.) or loads which are connected direct to the battery (inverter, etc.). See for option 2.2 current sensor HS200, too.

4.2.2 Overcharge Protection

The overcharge protection prevents uncontrolled gassing within the battery cells. The gas development is depending on the acid temperature and cell voltage. So the System-Manager monitors the ambient temperatures and adjusts the battery's maximum allowed charge voltage. The overcharge protection and voltage limitation is independent on the battery's state of charge, since the decomposition of electrolyte is exclusively depending on the voltage and the temperature. This means that charging is already limited even though the battery is not completely charged.

Overcharging the battery leads to uncontrolled gassing. Here the electrolyte is decomposed into oxygen and hydrogen. The consequences are harmful oxidation processes and mechanical damages since the gas blisters may knock out active lead material from the lead plates.

What is even worse is that the uncontrolled gassing in closed batteries e. g. sealed or fluid batteries where the gas pressure can even burst or crack the battery case. Frequent overcharging damages the battery casing. The charging process and the overcharge protection are thus regulated by a new hybrid System-Manager utilizing pulse width modulation in order to insure smooth battery charging. The user in particular should not choose a float voltage too high via user settings. If you want to program this value individually from the System-Manager's factory setting, please take note of the battery manufacturers' recommendations.

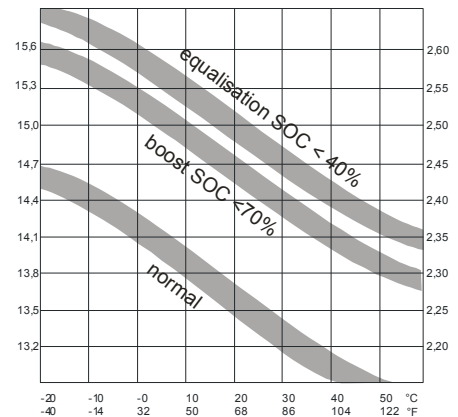

4.2.3 Temperature Compensation Of Final Charge Voltage

As the battery temperature increases, the acid/lead battery's optimal final load voltage decreases. A constant final charge voltage leads to uncontrolled gassing in the case of higher battery temperatures, and undercharging in case of low temperatures. The temperature compensation software algorithm automatically decreases the final charge voltage at higher temperatures and increases them at lower ones. The temperature compensation system with the sensor integrated in the System-Manager influences all three overcharge thresholds.

- The attached external battery temperature sensor should therefore be mounted next to the battery to determine the exact temperature.

4.2.4 Voltage Determination

Due to a special measuring method, battery sensor wires are no longer needed. The drop in voltage on the battery cable is compensated after the first full charge process. This is why no further sensor or wiring is needed, the installation is simplified, and the reliability of the system is increased due to the fact that sensors and wiring cannot break. However, measurements may not be as precise as with sensor wires. We would like to mention that – for a temperature coefficient factor of approx. 25mV per 1°C (changing of the final charge voltage with the ambient temperature within the 12V system) – a tolerance of 100mV corresponds to a temperature deviation of 4°C. There are no negative influences on the battery charging curves with such low deviations.

4.2.5 Energy Determination

The energy determination (SOC and Current readings) are calibrated on the lower energy range so within the maximum currents possible there may be deviations from an accurate electronic test meter. Please remember that this System-Manager is not a measuring device, but we have put these indications for your convenience.

4.2.6 Boost Charging (Lead&Sealed) And Equalisation Charging (Only Lead)

For this charging cycle, the System-Manager increases the battery charge voltage for a certain period of time after the battery has fallen below a certain SOC. The Boost Charge countdown is only activated when the desired battery voltage has been reached. This is the reason why it is important to pay attention to the fact that the solar module will be able give out sufficient charge energy with the corresponding final voltages.

You can manually activate the time limited boost charging.



If the Boost Charge voltage level is too high in comparison with the module voltage (reduced by wire losses) the countdown may never be started and your battery is therefore charged at a higher voltage with no time control.

Equalizing charge works similar to the above Boost Charging but is at an even higher voltage. Using equalisation charging is only possible and can only then be programmed if the battery has been configured to be of liquid electrolyte type. It is activated when the battery falls below a certain SOC status

4.2.7 Automatic Monthly Mixture Of Electrolyte

Batteries that are shallow cycled will never trigger the equalisation cycle, so an automatic function has been added so the final charge voltage is increased for a limited time every month. In this case, either Boost or Equalise charging is activated depending on the electrolyte configuration. This function prevents harmful acid layering which occurs especially after remaining a long time at a certain charge status.

4.2.8 Display

A double-line liquid crystal display (LCD) informs the user about important system parameters using various digital readouts. The first line of the LCD indicates SOC, battery voltage, load current and charging current in approximated “rough” values.

The second line scrolls through various information and system parameters and current status with more detailed values and descriptions.

The LCD works correctly only within the operating temperature range specified by the manufacturer. When this temperature range is exceeded, disturbances may occur which prevent reading the display. The display will return to normal when the operating temperature range is again reached. The storing temperature range, however, must not be exceeded or permanent damage may occur.

4.2.9 Overdischarge Protection

Overdischarging leads to sulphation and as result a loss of your battery’s capacity. The overdischarge protection feature disconnects the loads if the battery is becoming too discharged and re-connects them after sufficient re-charging. The loads can also be manually switched on/off, so the System-Manager can be used as a main DC load disconnect switch.

If the battery voltage falls under a certain voltage, the loads will be switched off, regardless of whatever values or manual adjustments have been programmed. (emergency cut-off)

The System-Manager is able to be converted into voltage regulation. After this configuration all values are able to program with voltage values. The discharge protection is now based on voltage and no longer on SOC which represent the acid density much better than voltage levels.

4.2.10 Control Keyboard

By using the tact switches underneath the LCD screen, the factory set values can be configured to the user's custom requirement. Freely programmable values can only be changed within a pre-set window. These minimum-maximum values are selected in a way that even extreme adjustments do not lead to severe damage to the lead batteries.

However, the operating elements are not protected or locked with a child-proof lock (code). For this and many other safety reasons, we would highly recommend that you make the System-Manager as well as the battery room inaccessible to children

4.2.11 System Voltage

The System-Manager adjusts itself automatically to 12 or 24 V system. For this it is necessary that the battery of the proper voltage is connected to the System-Manager first.

There are two variants of the System-Manager: one for the system voltages of 12/24V and another 48V version. The 12/24V System-Manager only adjusts itself for system voltages below 30 V. For 48 V systems you will need another model with more voltage-stable components. Please have a look at the marks on the case for information if your System-Manager fits the desired system voltage.

5 Indication Of Status

5.1 LC-Display

The two-line display indicates all present system values in short form on the top line, and the values are without units (Volt, Amp, etc) due to a lack of space. Here as a reminder: the meaning of the first display line:

State of charge SOC	battery voltage Bat	charging currents IN	discharge currents OUT
------------------------	------------------------	-------------------------	---------------------------

The second line constantly changes its information. All values and system information are indicated alpha-numerically. The following displays can only be seen during regular operation (not while programming).

```
SOC  Bat  IN  OUT
98% 13.7 26 17
SOC = 98%
```

SOC means "state of charge" and indicates how much remaining capacity the battery still has. The SOC is never 100% as due to technical reasons it is easier to indicate a

two-digit number.

```
98% 13.7 00 00
U Bat = 13.70V
```

U Bat: Since the voltage drop between System-Manager and battery can be calculated without sensor wires, this display shows the battery's actual voltage at the battery poles, and not the voltage at the System-Manager's connection terminals.

```
78% 12.9 25 00
I in = 25.4A
```

I_in is the sum of the charging currents flowing into the battery. It is composed of the solar module current running through the System-Manager and the charging current of further charging generators that are directly connected to the battery via an optional external HS200 current sensor . If no shunts are used, I_in indicates only the solar charging current.

```
67% 12.4 00 17
I out = 17.0A
```

I_out is the sum of discharge currents flowing out of the battery and is composed of the load current running through the System-Manager and the discharge current of loads that are directly connected to the battery via an external HS200 current sensor.

```
98% 13.7 04 02
I mod = 21.5A
```

I_mod is the charging current produced by the solar modules. It is less than the short circuit current (which is not displayable anyway). When the voltage of the battery is getting near the final charge voltage(see example), the module current I_mod is substantially higher than the charge current (I_in). "I_in" will be regulated by the System-Manager in order to protect the battery from being overcharged.

```
83% 13.4 25 20
I accu = +05.4A
```

I_accu is the balance of all charging and discharging currents. As long as the charging current is higher than the discharging current, the value is positive, in the opposite case, it is negative.

```
98% 13.7 65 00
modul current
```

Messages such as "over-temperature", "load current", "low voltage" and "over voltage" are warning signs The System-Manager automatically takes steps in order to protect

itself, the battery and the loads. After the error condition ceases to exist, the System-Manager resumes normal function.

87% 12.7 00 02
I_mod = night

The System-Manager can determine night time from the solar module current. The condition "night" is shown instead of the actual module current. The night condition can only be determined if no reverse blocking diodes between the modules and the PowerTarom are used.

Another feature of the System-Manager recognizes whether a solar module has been connected or not (I_mod = no modul). This status is displayed and is also sent to the external data logger. This signal can be used as theft recognition only if the solar module array is completely disconnected, as this feature does not recognize the disconnection of single strings in the array. The "no module" detection needs between 15 and 60 minutes to be raised. If blocking diodes are used the "no module" message appears during the night instead of the "night" message..

99% 14.7 15 00
boost charge

System-Manager status such as "normal charge", "boost charge" and "equal charge" indicate which stage of charging is in process. After a certain period of time of operating in the "boost" and "equal" charging modes, the normal charge mode is resumed. "Deep protection" (meaning the System-Manager has decided to disconnect the loads to protect the battery from deep discharge) is also indicated on the display, even when automatic load disconnection has been de-activated.

20% 11.4 03 23
manual auto

System configuration settings such as the selection of the electrolyte "liquid electrolyte" for liquid batteries or "fixed electrolyte" for sealed batteries as well as manual load disconnection "manual auto", "manual load off" or "manual load on" are indicated.

5.2 Alarm contact

All PowerTaroms are equipped with a signal contact.. See illustration in chapter 6.4 to locate the terminals. The signal relays switches if a system fault occurs: under/over voltage, overcurrent; >110% max. current, SOC < 30%, overtemperature, no module connected, no charging during the last 24 hours. If one or more of this events occurs the terminal contacts #5 and #6 close and #5 and #4 opens. The error conditions resets automatically if the reason has stopped. Since software version 12.25 the SOC alarm will close if the SOC falls 10% below the user defined load disconnect value. Since the default load disconnect is at 30% the default alarm will come at 40% SOC.

The max. switching power of the contact will be 150 mA, 200V DC. Rds on = 35 Ohm.

Voltage Error Conditions

System voltage	12V	24V	48V
Undervoltage	10.5V	21V	42V
Overvoltage	15V	30V	60V

6 Operating The System-Manager

6.1 Factory Pre-Set Configurations

With the factory pre-set configurations, the System-Manager can be used in most applications without further programming.

On delivery, the System-Manager is always set with these pre-set basic configurations that enable immediate use of most typical solar systems after installation. This pre-set configuration match most PV systems' demands. We recommend only specialists and authorized dealers to change this factory configuration.

The System-Manager can at any time be reset to the factory pre-set configurations with the Menu CONF (chapter 6.5, page 13 facility). NOTE: you must set the battery type with the Menu CONF. Since this setting is even necessary when no custom programming is desired, this manual provides a detailed Example Of Configuration (chapter 6.7, page 16) for your convenience. All other parameters should only be changed if you have sufficient information on the battery in use.

With this System-Manager, the user of a photovoltaic solar system has the possibility to design his own unique solar power system. This is made possible by various configuration alternatives for parameters and functions.

In the following section you will find information on how to change readings, parameters and functions. Menu windows clarify possibilities on what to select and give an overview on the menu-driven use of the System-Manager.

6.2 Main Menu

Set values and functions can be adjusted with the four control keys under the safety cover lid. By pressing any one of these keys, a Main Menu appears in the display – MANU (manual adjustments during operation), LOGG (inquiry of internal data logger), CONF (configuration of system components) and PROG (programming set values). By pressing the key below the corresponding abbreviation, you can enter the corresponding menu.

Other than this Main Menu, the keys always have the normal functions described below to navigate through menus:

⇒ With the arrow keys ▲▼ you can scroll through the submenu items, but no values appear and no parameters can be changed by this scrolling action.

⇒ By pressing OK the displayed menu window is activated, and the value is indicated. Pressing OK once again leads to a closure of the window without adjustment.

⇒ After a menu window is activated and its value is displayed, use the arrow keys ▲▼ to can change the value. When the maximum value has been reached, the parameter starts at the lowest value again. By constantly pressing the key, the value starts to scroll in small steps.

⇒ Confirmation and storage of the new value is done by pressing OK

⇒ if no selection of another menu is made within 5 seconds after OK is pressed, the System-Manager will automatically exit from all menus and the normal indication of running status appears .

⇒ If there are no adjustments for 2 minutes on an activated submenu value being changed, the display indication jumps to the main menu and the adjustment in the open window is not stored or applicable.

⇒ The MENU key will bring the display back to the Main Menu.

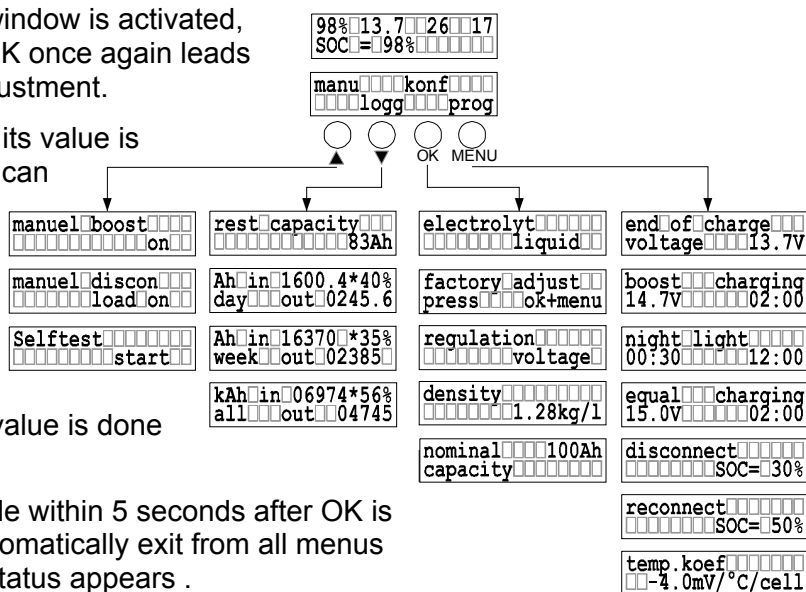

6.3 Menu MANU

Here you have the possibility to directly influence the System-Manager's behavior

manual boost Manual boost charging increases the final charge voltage to set values for a limited period of time. Having reached this window, it can either be skipped the arrow keys ▲▼ or entered by pressing OK. After entering with OK you have the possibility to activate boost charging with the arrow keys ▲▼.
possibilities for programming: on, off

manual discon Within this window, the load can manually be connected or disconnected. By pressing OK you enter this window and you may then switch $\sigma\tau$ from "load on" to "load off" or "auto". However, the battery will still be protected from the worst discharge by an emergency cut-off that cannot be overridden by the manual control function. "load off" switches off all loads and may be used as main switch if you leave your solar system for a longer period of time. "auto" automatically protects the battery from being deep discharged.
possibilities for programming: load on, load off, auto

self test Before this menu function is activated, it is necessary to disconnect the solar PV modules and all loads. Before Uninstalling (chapter 7.5, page 20) please refer to the related information. After having scrolled to this window, a self test can be started by pressing OK. The System-Manager examines its performance components: software and parts of the hardware. When the window appears "TEST MODUL OK; TEST LOAD OK", the operation and hardware have been

related to the calculated state of charge of the battery.

After entering this menu, by pressing OK you may switch with the keys ▲▼ between SOC and voltage.

possibilities for programming:

SOC, voltage

associated SOC in setting "regulation = voltage"

SOC	12V system	24V system	48V system
0%	< 10,9 V	< 21,8V	< 43,6V
10%	10,90 - 10,99V	21,80 - 21,99V	43,60 - 43,99V
20%	11,00 - 11,09V	22,00 - 22,19V	44,00 - 44,39V
30%	11,10 - 11,69V	22,20 - 23,39V	44,40 - 46,79V
40%	11,70 - 11,99V	23,40 - 23,99V	46,80 - 47,99V
50%	12,00 - 12,49V	24,00 - 24,99V	48,00 - 49,99V
60%	12,50 - 12,69V	25,00 - 25,39V	50,00 - 50,79V
70%	12,70 - 12,79V	25,40 - 25,59V	50,80 - 51,19V
80%	12,80 - 12,89V	25,60 - 25,79V	51,20 - 51,59V
90%	12,90 - 12,99V	25,80 - 25,99V	51,60 - 51,99V
99%	> 13.00 V	> 26V	> 52V

density 1.28
1.28kg/l

Within this window, the acid density can be configured. After having entered this menu, press OK and the acid density can be edited using the arrow keys ▲▼. and press OK again to save the value. When the System-Manager is set for the use of sealed batteries, this window is not accessible, since the acid density cannot be configured for sealed batteries.

possibilities for programming:

1,20...1,30kg/l

nominal capacity 100Ah

Within this window, you can register the batteries nominal capacity. press arrow keys ▲▼ for changing the nominal capacity and press OK for entering the new value.

Hint: We recommend this reset in case you are using a second-hand System-Manager, or if you intend to move the System-Manager to another system or change the battery.

6.6 Menu PROG

Within this menu, various charging and special function settings can be changed within the below windows. We have tried to insure that the values are limited within ranges that do not damage the battery immediately. However, certain skills are needed as far as battery behavior is concerned to prevent long-term damage or poor system performance. If you are unsure about any of these settings, please refer to your authorized dealer or leave the pre-set configurations as they are.

In order to adjust the values, first press OK to enter the edit mode for any of the below windows, then edit the value with the arrow keys ▲▼ and press OK to enter and store the value. You will find a detailed Example Of Configuration (chapter 6.7, page 16) describing how to proceed.

end of charge voltage 13.7V

The end of charge "float" voltage serves for maintaining the charge in the battery for long periods and preventing self-discharge. This voltage should not be too high, since this may lead to permanent gassing, which damages the battery. Maximum values are stated on the battery data sheet of your battery. For most types of lead battery, this float value is 13.7 volts.

possibilities for programming: 13,0V...14,5V | 26,0V...29,0V | 52,0V...58,0V

boost charging 14.7V 02:00

Increasing the charge voltage over a limited period of time (boost or "bulk" charging) is not harmful for lead battery types, if within certain parameters. Maximum values are stated on the battery data sheet. Within this window, both the boost charge voltage and the period can be programmed, how long the boost charge should be activated. After having entered the window by pressing OK, the first line shows "Boost__voltage" and you may alter the voltage appearing in the second line by pressing the arrow keys ▲▼. By pressing OK, the window "Boost__time" appears and you may adjust the time period. Both of these settings are confirmed by OK and stored.

Possibilities for programming: in the period from 00:30...05:00 : 13,5V...15,0V | 27,0V...30,0V | 54,0V...60,0V

equal charging 15.0V 02:00

The equalisation charging can be programmed similar to adjusting the boost charging. Press OK to enter, edit the equalisation charge voltage by pressing the arrow keys ▲▼, then press OK to edit the adjustable time period, and confirm both settings by pressing OK. The equalisation charging can only be adjusted for batteries with liquid electrolyte, since high equalizing voltages are harmful for sealed batteries. The maximum equalizing voltage value should be stated on the battery manufacturers' data sheet.

This window is deactivated if you have selected "Fixed" within the menu CONF (under selection of electrolyte). Factory Pre-Set Configuration presumes liquid electrolyte batteries. You will find a detailed description in chapter 6.7.1, page 16

Possibilities for programming: in the period from 14,0V...15,5V | 28,0V...31,0V | 56,0V...62,0V

 Battery charging voltage is passed on directly to the loads by the System-Manager! Therefore, during equalize charging, high charging voltages can be programmed that may damage some loads. Please select this equalize charge voltage very carefully and compare the desired value to the battery and load (appliance) manufacturers' data sheets.

 The discharge threshold at which the loads are automatically disconnected can be programmed by the user. When you have reached this window by pressing the arrow keys ▲▼, you may open it for editing by pressing OK. Afterwards you may alter the disconnect threshold by pressing the arrow keys ▲▼ within given values. Press OK to store the setting. NOTE: the difference between disconnect and reconnect threshold must be at least 20%. If you wish disconnect at higher state of charge you have to first adjust the reconnect threshold (as per below) to 20 % above the desired disconnect threshold. Under voltage regulation this difference is at least 0.8V in 12V systems.

Possibilities for programming by SOC: (disconnect) 20%...70%
Whenever you configure voltage regulation (chapter 6.5; page 13) you will find in this window voltage values instead of SOC values for programming the disconnection voltage level. Be aware that the System-Manager allows only these values for disconnect and reconnect in order that a minimum difference of 0,8V (12V), 1,6V (24V) und 3,2V (48V) is assured. If you want to program a high level for disconnection you must first increase the reconnection level.

Possibilities for programming by voltage regulation: 11,0V...12,5V | 22,0V...25,0V | 44,0V...50,0V

 The charge threshold at which the loads are automatically reconnected, can also be programmed by the user. The reconnect setting window is reached by pressing the arrow keys ▲▼. Enter the window by pressing OK, and alter the values within the window. Press OK to store the setting. The reconnect level can only be reduced to 20% above disconnect threshold (see above).

Possibilities for programming: by SOC: (reconnect) 40%...90%
Whenever you configure voltage regulation (chapter 6.5; page 13) you will find voltage values instead of SOC in this window. The System-Manager will only allow to program values which are possible to guarantee the minimum hysteresis

Possibilities for programming: by voltage regulation: 11,8V...13,3V | 23,6V...26,6V | 47,2V...53,2V

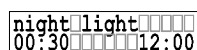
 The System-Manager can control night lighting automatically by evaluating the density of outside light with the help of the solar PV module array. Depending on the PV array alignment or shading, it may well be that night recognition is activated even though twilight has not yet come to an end. By the programmable time adjustment "night delay", the night light switch-on may be shifted to a later time. When you have entered the window by pressing OK, the first line displays "night__delay" and you may change the time of delay by pressing the arrow keys ▲▼. After confirmation by pressing OK, the display "night__timer" appears and you may enter the period of time for the light to remain on after dawn. By pressing OK both of these settings are confirmed and stored. This configuration setting has no actual effect on the System-Manager or its load output terminals. However, loads which are required for night time use, can be especially connected with the PA15 remote control switch and the PA15 have to be programmed to nightlight and the System-Manager sends a signal which activates the loads.

Possibilities for programming: timer 00:00...12:00 and delay of 00:00...03:00

 The gassing which occurs in the battery (only in liquid acid vented cap type batteries) is proportionate to the voltage and the temperature. The higher the voltage and/or temperature goes, the more gas will be produced inside the battery. So in accordance with the temperature, the voltage value has to be changed to control the gassing process to occur only during the equalizing charge. The charge voltage settings (float, boost, equal) refer to the setting at room temperature (25° C) and are altered internally by the programmable coefficient in accordance with the ambient temperature registered by the System-Manager's temperature sensor.

Possibilities for programming: -2mV/K/Zelle...-8mV/K/Zelle

6.7 Example Of Configuration

6.7.1 Factory Pre-Set Configuration

After a DC power failure from an occurrence such as blown safety fuses or disconnecting the battery, usually no parameter values or functions have to be programmed again, since these values are stored in the System-Manager's EEPROM (a special memory chip that does not lose its data on power failure). Please note that these configurations are even stored when you remove the System-Manager and reinstall into a new system.

Hint: Used System-Managers should always be Reset To Factory Pre-Set Configuration (chapter 6.7.3; page 16) before putting into operation in a new system.

For details of the factory pre-set values please see under controlling data 8.2. The user can reset to this factory configuration at any time. However, any previous configuration settings will be lost.

Hint: Adjust the battery type after reset!

On delivery, the System-Manager is factory pre-set for vented batteries with liquid electrolyte "liquid". This configuration is applicable for most typical vented-cap lead acid batteries. However, setting this parameter to the other setting for closed batteries with gel electrolyte "fixed" leads to optimal charging and safe maintenance function (no equalize charge or gassing allowed).

Only with the configuration "liquid" will you have the possibility to program the acid density and the equalizing charging "equal charging". When the configuration is set to "fixed" these windows are not activated.

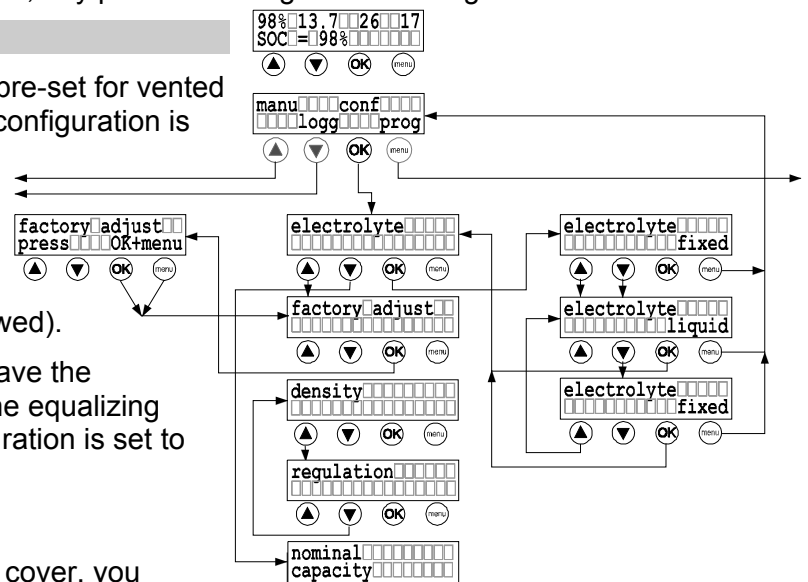

6.7.2 Battery Type

By pressing any one of the 4 keys under the cover, you leave the online status display and go to the main menu. By pressing the key below the corresponding abbreviation: MANU (manual alterations during operation), LOGG (Checking the internal data logger), CONF (configuration of system components) and PROG (programming of set values), you can enter the corresponding menu. In the case of this example you have to press the third key from left (labeled OK), which is below the abbreviation CONF. This is how you get into the window for programming the electrolyte.

Hint: If you have pressed the wrong key, press MENU to get back to the main menu and start all over again.

If you press OK again now, you will enter the electrolyte setting window and you may toggle between the settings "fixed" and "liquid" by pressing the arrow keys ▲▼. After having selected the desired configuration, press OK to confirm the configuration. Now you are free to either enter further windows by pressing the arrow keys ▲▼ or to get back to the main menu by pressing the menu key.

6.7.3 Reset To Factory Pre-Set Configuration

In the previous section, it is described how to enter the window electrolyte. The next window down is for resetting the System-Manager to the factory pre-set configuration (factory adjust). If you use the UP arrow key ▲, however, you will wrap around to the nominal capacity setting window instead, and only by repeated pressing of the arrow key ▼ via regulation and density you will get to factory adjust (see the menu tree chart). By pressing OK you can enter the factory adjust window. The instruction to press the MENU key plus the OK key appears immediately. Only by pressing both of these keys simultaneously will the factory pre-set configurations be set.

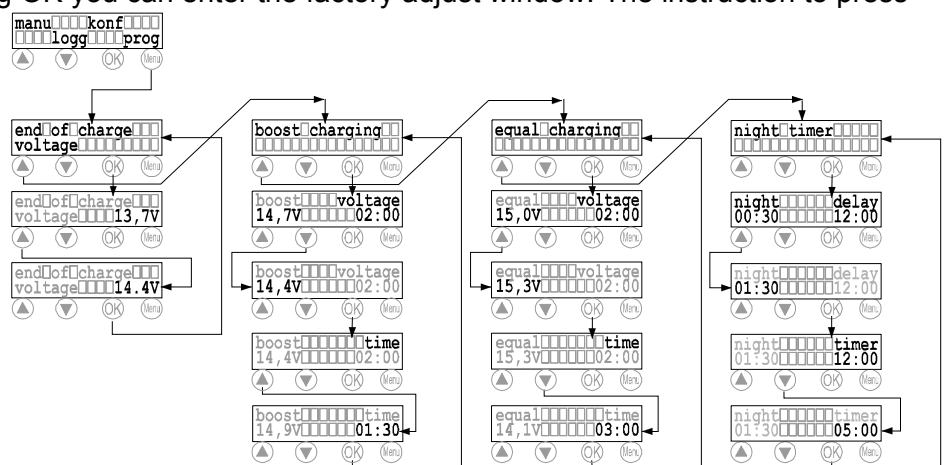

6.8 Example Of Programming

This example shows how pre-set configurations can be

altered within the main menu item “PROG”. Changes are displayed in black letters.

First of all, open the cover of the System-Manager, and press any key. The Main Menu with the four submenus will appear in the display. Please press the key below the corresponding submenu title (MANU, LOGG, CONF, PROG). In this example, press the very rightmost key under PROG. Note that this key has the function “return to Main menu” in all other windows.

After having pressed this key, the topmost item of the PROG menu “end of charge” appears. Since we are not concerned with this item, we scroll past this window and move to the window boost charging by pressing the UP arrow key ▲. Once we reach the desired item “equal charging”, then press the OK key to activate the window. The first line indicates the expression equal voltage and you may change the voltage value (here 15V) to 15.3 by pressing the arrow keys. By pressing OK, this value is stored, and at the same time the expression equal time now appears in the first line. Now you can adjust the time that the increased equalizing charge voltage should be maintained by pressing the arrow keys ▲ ▼ (here: from 02:00 to 03:00). Press OK for confirmation and the original window for equal charging appears.

Hint: If you want to make sure that you have programmed correctly, press only OK and move through all Equal Charging submenu items to check the values. Do not press the arrow keys to avoid changing the values.

Hint: If you have programmed a wrong value, you will again reach the window with the undesired value by pressing the OK key a few times. When you have reached the window with the error, change the value to the correct one by pressing the arrow keys ▲ ▼.

7 Installation

7.1 Precautions

Do not install any PV or electronic components in rooms where flammable gas mixtures may occur!

Within the battery’s immediate surroundings, explosive gases may be generated. So please see that the battery room is adequately ventilated and avoid generating sparks.

⚠ The following instructions for batteries must be adhered. We recommend these basic precautions for any country. Check your local electric and safety codes for all applicable precautions in dealing with DC wiring and battery installations.

⇒ DIN (German) VDE 0510 part 2, sections: 7. Precautions against explosion danger, 8. Precautions against risks occurring by electrolyte gas (hydrogen sulphide) and 9. Location

⇒ National Electric Code including article No. 690. The unit shall be installed according to this regulation

7.2 Location Of Installation

The System-Manager must be connected to the solar PV array, the battery and the loads. The line loss and drops in voltage should be kept to a minimum, so the System-Manager must be installed in a way that the shortest cable possible and the most direct access can be used. This is a major decisive factor for the battery’s location as well as for the solar PV array’s location. The cable lengths to the loads have a lesser effect on System-Manager site selection since distribution throughout the building or site is necessary.

The ideal location for the battery is a well-ventilated battery room (keeping a minimum safety distance of 30 cm from the System-Manager) inside the building but nearest to the solar PV array. Since both charging and discharging currents are running via the battery cable connections, close proximity and short thick cables to the battery are recommended. This battery cable connection is the point where the losses have the worst effect on the PV system’s efficiency and performance.

The solar PV array should be installed in a way that – in the most unfavorable case – the voltage drop is not so high that the battery can not be charged completely again. Within the limited period of time for equalize charging, the battery is charged at a high voltage level. However, if the drop in voltage along the PV array cables is too high, this equalizing charge voltage cannot be reached. The timer for the

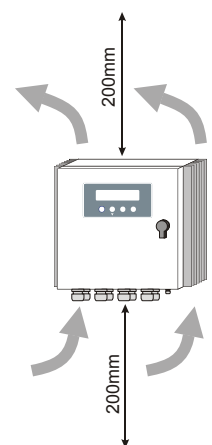

equalize charge stage will not start running until the equalize voltage is reached, so the timer will be “stuck” and the System-Manager will stay in equalize mode permanently until the situation is corrected. For example, if the MPP voltage at the PV array connection is 16.5V, minus 1.0V drop in voltage on the PV array-to-System-Manager wiring, minus 0.3V drop in voltage at the System-Manager and the safety fuses, the maximum voltage reaching the battery is only 15.2V.

The System-Manager must not be installed in locations with easily flammable liquids or mixtures such as gas bottles, paint, varnish, solvents etc.. Installation is only permitted in areas where the System-Manager’s environmental specifications are not exceeded (see technical data) . Furthermore, the System-Manager must not be installed and operated in very humid rooms e. g. bathrooms.

The System-Manager must be protected from direct exposure to weather. Sun and external warming from nearby devices should also be avoided.

The battery and the controller must be out of children’s and unauthorized persons’ reach. The basis on which controller is to be installed should not be easily flammable. During operation the backside of the controller (cooling body) heats up by the loss performance and so the location for installation should persist a temperature of 85°C.

7.2.1 Installation on walls

The regulator has to be mounted on fire proofed basement. Furthermore no inflammable material is allowed under the place regulator is mounted.

The controller is to be installed on vertical walls. This is the only way that the controller can be cooled by surging air (chimney effect) and work correctly.

The system controller is screwed to the wall with the 4 supported wall hinge. See illustration.

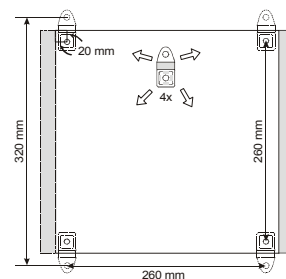

7.2.2 Mounting the system controller

The controller must be installed with cable openings down. Make sure that the cooling body is aerated when mounting. When the controller is in operation, producing loss performance that warms up the device air is surging on the cooling body and extracts the heat. This chimney effect is necessary for perfect operation. Do not shut up the controller since this would make aerating impossible. Adhere to a safety distance of min. 200 mm.

7.3 Preparations

7.3.1 Assembly

Principally before installation set all cables, feeder boxes and safety fuses:

- cut into sections
- isolate on both sides and press on end sleeves for strands
- prepare feeder boxes

7.3.2 Preparation of wiring

Please make sure that the wire diameter is in accordance with the controller’s performance. The following table states the minimum cross sections that are necessary referring to constant currents. Distance from regulator to the module distribution panel (approx. 10m); to battery (approx. 2m); load distribution box (approx. 5m).

current	diameter	AWG	Isolation
20A	10mm ²	8	85°C
50A	25mm ²	4	85°C
70A	35mm ²	2	85°C
140A	70mm ²	2/0	85°C

Before wiring please check if the batteries are the right ones and if they are connected to the circuit the right way (check system voltage!). Also make sure that the solar generator’s maximum solar current does not exceed the connecting value of the controller.

7.3.3 Cabling

Solar modules create currents in the case of light incidence. Even in the case of slight light incidence full voltage is given.

- Solar modules must in no case be set free of voltage by short circuit! Spark development!
- Only use well-isolated tools!
- Never touch blank cable ends!
- Isolate each blank cable end if not connected immediately!

- Work only on dry underground! Components (module, cables etc.) must not be wet or moist for installation!
- Pay attention to the right polarization during cabling!

The battery stores a substantial quantity of energy that may be set free during a short circuit and that may evoke fire if not secured adequately. So it is indispensable to install a safety fuse directly on the battery pole. This fuse secures the cables between controller and battery.

For isolated systems it is not necessary, not common or even not permitted by national laws to ground-connect the components (e. g. DIN 57100 part 410). For further instructions please see Safety measures (chapter 7.6, page20)

7.4 Installation and operation

It is absolutely necessary to adhere to all our General Safety Instructions (chapter 1.3, page 3). To guarantee a faultless working of the controller it is necessary to follow the chronological sequence described in the following chapters.

Important: Check right polarity prior to connecting, all negative (–) terminals are marked blue!

7.4.1 Connection the battery to the controller

- switch the circuit breaker in the controller to OFF (0)
- Lay accumulator connecting cable (A+, A-) between system controller and battery storage parallel.
- Pay attention to the right polarity!
- Connect battery connecting cable A+ to the battery's positive pole
- Connect battery connecting cable A- to the battery's negative pole
- Switch the circuit breaker to the ON (1) position, the controller should start to work
- If you switched off the controller wait 10 s before restarting it again.

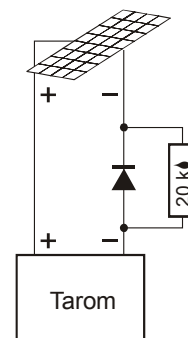

7.4.2 Connecting the solar generators to the controller

- Connect both module groups with M+ and M- to the controller's terminal screws. Pay attention to the right polarity to avoid damage to the regulator! Blue terminal is negative (–).
- Connect solely solar generators as energy source (no net devices, diesel or wind generators).
- If you use blocking diodes to separate module strings, you should parallel one of these diodes with a 20 k Ohm resistor to enable the module and night detection of the PowerTarom. Otherwise the regular functions are ok but Ah counter will not operate.

7.4.3 Connecting the loads

- Protect each load circuit by a safety fuse
- Disconnect all loads before cabling the load cables in order to avoid spark development.
- Connect load cables to the controller's terminal screws. Pay attention to the right polarity!

7.4.4 Connecting the temperature sensor

- Fix the temperature sensor to a battery pole.
- Connect the sensor with the terminals 7 and 8 of the printed circuit board.

7.4.5 Connecting the alarm contacts

- The signal relays switches if a system fault occurs: undervoltage, SOC only 10% over disconnect value, overvoltage, ... (see 4.2 alarm contact).
- In case of an alarm the terminal contacts #5 / #6 close and #5 / #4 opens.
- contact load max. 150 mA, 200V DC. Rds on = 25 Ohm.
- The error conditions resets automatically if the reason has stopped. See chapter 4.2 too.

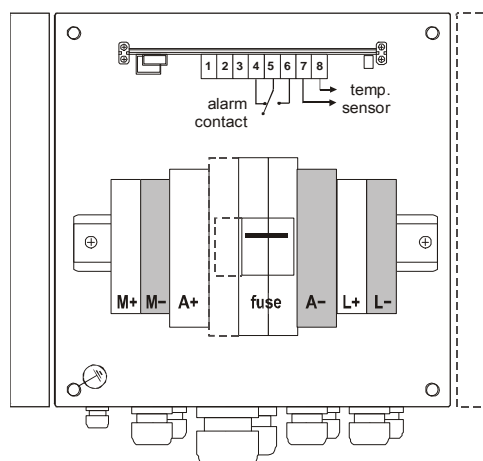

Connect loads that must not be disconnected by the controller (e.g. emergency light, radio link) directly to the battery! Increased risk of discharge no longer controlled by the system controller! Secure these loads by installation of safety fuses.

Finally secure all cables within the controller's immediate surrounding by strain relieves. All other components must also be strain-relieved.

7.5 Uninstalling

Uninstall the regulator in the opposite way like installing. Firstly all consumers must be switched off by hand and then disconnected from the controller. Secondly the modules must be disconnect. To avoid any sparking the modules had to be disconnected at night or covered. Now the fuse can be removed.

In order to avoid short cuts you have to remove the junctions from the battery poles before you disconnect the cables from the controller. Before reinstalling the controller it should be reset to the factory adjustment.

7.6 Safety measures

All safety measures for the solar charge controller's protection cannot prevent any impact caused by wrong installation outside the controller. This is the reason why we urgently recommend the installation of a safety device on the battery pole in order to prevent short circuits between battery and controller.

7.6.1 Electronic short circuit safety

An electronic short circuit safety device prevents both destruction of the controller and the safety device's release in the case of short circuits on the solar generator and consumer components exits. The display indicates this error as „load current“. After elimination of this fault the controller automatically switches to normal operation after 30 seconds.

7.6.2 Hardware safety

The controller has been protected by a magnetic circuit breaker. The controller power range (page 5) can be taken from the SOAR diagram.

7.6.3 Flammability

The controller is solely made of non-flammable and self-dissolving material. Even in unpredictable error situations there is no risk of fire if there is no flammable material within the ambient surrounding and if the controller has been installed on a fire-proof underground.

7.6.4 Simple and double errors

The controller is protected from simple errors (e.g. load short circuit, battery polarization, module polarization etc.) by appropriate measures, mainly electronically or by fuses.

However, there are some double errors that may lead to the destruction of the controller or components (consumer components, modules), such as:

- Polarised battery on the solar entrances
- One battery wire on the module entrance, the other on the load exit
- A wrong source (grid with 230V) on the solar entrance

8 Overvoltage protection in your photovoltaic system

Over voltage can damage your PV system

Photovoltaic systems have to be mounted very often on sites like mountain tops or next to high structures like transmission poles. These locations have a high risk of damages due to lightning. Harmful levels of over voltage will occur through direct hits or even more frequently induced by flashes as far as 100 meters. To prevent your electronic equipment from these damaging over voltage spikes, you have to include all parts of your system into the over voltage protection: building, modules, frames, wires, controller, inverter, loads, antenna and grounding.

In any case, a good lightning protection can reduce the risk of damages in a great measure, but not prevent them completely. We can give you some hints for further reading, but it is not possible to describe the overvoltage protection for all installations in detail here.

See these sites for more recommendations for lightning protection

<http://www.iea-pvpsuk.org.uk/PV%20for%20standalone/T3-13%202003.pdf>

or check the internet sites from producers of over voltage protection units:

...

transient over voltage spikes

Transient voltage spikes can be caused by effects of lightning. It's not necessary that the system got a direct hit – in this case the energy is normally that high that the degree of destruction is obviously.

Even a discharge between clouds or a strike far away can induce energy pulses into the electrical conducting parts of the installation like wires, metal structure or electronic components.

Not even a visible and/or audible lightning strike with thunder can cause a transient voltage spike. Also discharges of electrostatic charge may cause transient spikes of some 1000 V ! Such transient voltage spike can be a positive or a negative pulse related to the ground.

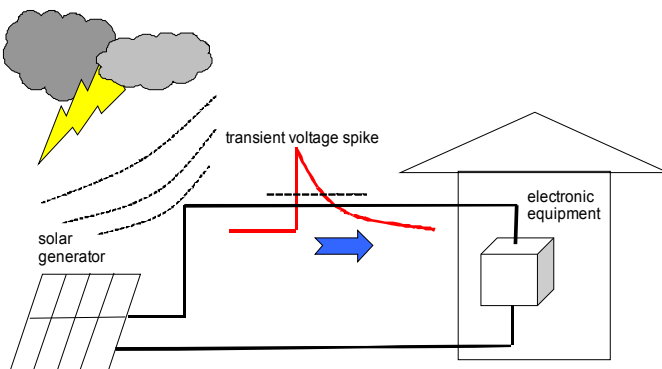

High voltage spikes induced by distant lightning

Internal overvoltage protection

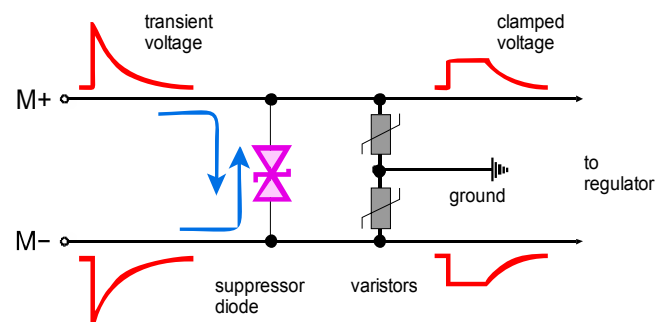

Inside the PowerTarom there are electronic components (varistors and suppressor diodes) to limit the energy of transient spikes. These elements normally absorb some limited energy and convert them into heat. If the power is too big even these elements will be destroyed by overheating.

Some general hints for the over voltage protection in your system:

- grounding of the plus (+) pole of the battery helps to reduce the transient voltage level. All plus (+) terminals of the PowerTarom regulator are internally connected.
- the module frames and the mounting rack should be grounded. The module cables to the regulator should have been shielded.
- all connections to the ground have to be as short as possible
- the connections between regulator and modules should be as short as possible
- the + and – cable of the modules (and the load) may not be separated to avoid loops between them

- external over voltage protectors have to be used at the module junction box (expulsion-type arrester, varistor, suppressor diode with $\geq 10\text{kA}$)
- lay grounding cables separately to the DC cables

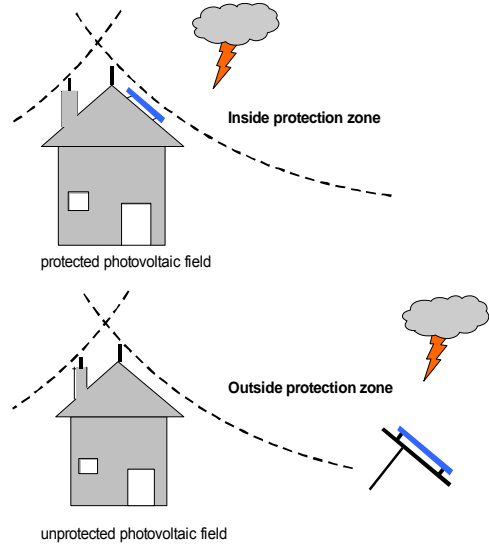
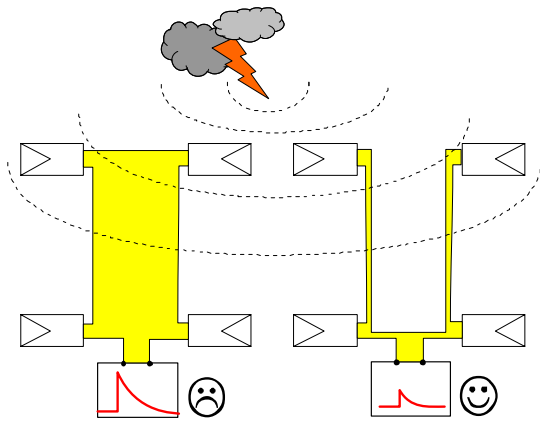

avoid loops between module cables

keep modules and lightning protection next to each other

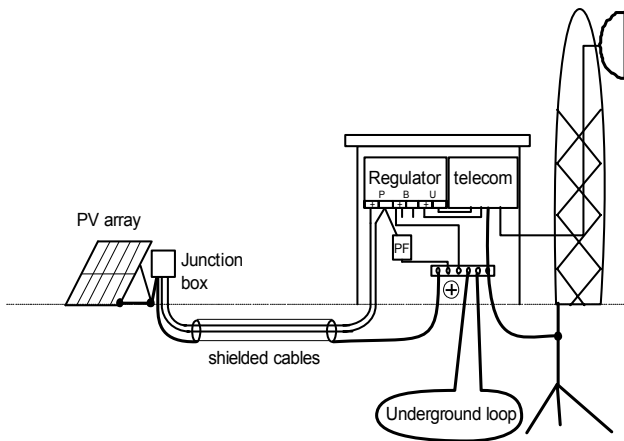

The connection between modules and charge regulator should be shielded. All metal parts should be grounded. Lightning rods can help to protect from voltage spikes but they should not shadow the modules at any time.

The module junction box should contain an expulsion-type arrester and/or a suppressor diode and a varistor with a high energy capacity (15 kA). The limited voltage should be just above the open circuit voltage of the modules.

9 Grounding

9.1 Positive grounding

When a grounding at the plus-side is chosen, it can also be taken as common mass for all system components. All plus connections are internally connected anyway.

9.2 Negative grounding

Only one minus connection of the components module, accu or load can be grounded. (e. g. grounding of aerials)

When your solar system determines a minus mass (e. g. accu minus) only this component can be connected with this mass. A connection with further minus poles (module or load) bridges control

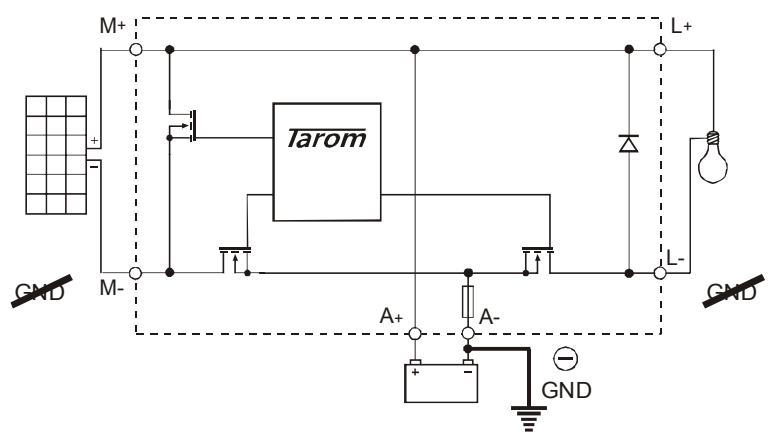
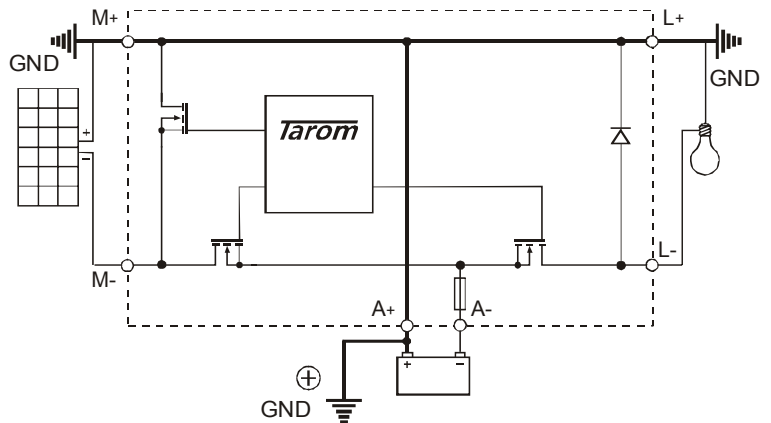

elements and the fuse. This can lead to a malfunction and destruction of the controller.
The metal case is not connected to a battery potential.

10 Hints for the usage of multiple PowerTaroms

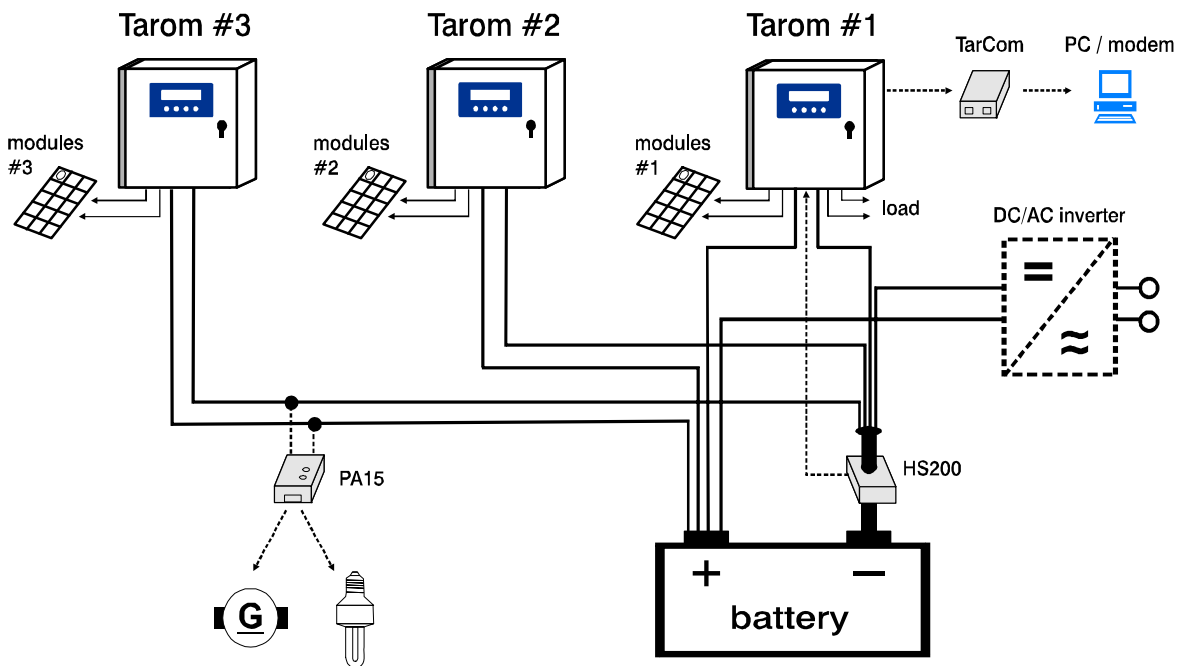

In a photovoltaic system several PowerTarom regulators can charge a battery simultaneously. Please note the following notes for an optimal installation:

battery: the battery terminals (A+ and A-) of all regulators are connected to the same battery

modules: each PowerTarom needs an individual, separate module group. No connection or grounding is allowed between the several M terminals.

load: do not connect the L terminals between several PowerTaroms.

grounding: only the + terminals of different PowerTaroms can be connected or grounded. Never connect or ground the M or L to the battery minus!

Configuration of the PowerTaroms:

Tarom #1

set regulation to "voltage" (menu conf/regulation/voltage)

set electrolyte type corresponding to your battery (menu conf/electrolyte/liquid|fixed)

Tarom #2, 3, ..

set regulation to "voltage" (menu conf/regulation/voltage)

accessories:

data logger TarCom: The TarCom logger can communicate to a single PowerTarom only. So the currents data of the other PowerTaroms are not registered. You can use for each PowerTarom a several TarCom or you install instead a HS200 current sensor in the battery main line.

current sensor HS200: If you attach a HS200 to the main battery cable, all currents going in and out the battery are calculated and displayed at this PowerTarom and his TarCom logger. You only need one HS200 for the whole system. Currents higher than the maximum of 200A will not be displayed but do not harm the sensor. If you use a HS200 sensor together with Tarom #1 you can reset its configuration menu/regulation to "SOC".

receiver PA15: only one PowerTarom may supply the radio signals for the PA15 receivers. Set the "option transmit" to "accu" at Tarom #1 and set "option transmit" to "off" at all other PowerTaroms in the system.

11 Maintenance

Since there are no moving parts (fan or relays), no maintenance is necessary for the controller itself.

The heat sink must be kept clean to assure cooling.

As far as the cables are concerned they must be checked on corrosion. Due to corrosion the transfer resistance increases and the contacts could become so hot that defects arise.

12 Technical data

12.1 Performance data

Type of controller	2070	2140	4055	4110	4140
Systemvoltage	12/24V		48V		
Max module current I_k 20°C	70A	140A	55A	110A	140A
Max discharge at 20°C	70A	70A	55A	55A	70A
Max. module voltage	50V		100V		
Operating temperature	-15°C...50°C				
Storage temperature	-15°C...80°C				
Terminals Batt/Module AWG	0 (50mm ²)	0000 (95mm ²)	0 (50mm ²)	00 (70mm ²)	0000 (95mm ²)
Terminals load AWG	0 (50mm ²)				
Cable glands and Cable diameters	PowerTaron 2070 and 4055 (one heat sink) : 2x M40 (Ø14...28mm), 4x M32 (Ø12...21mm), 1x M25 (Ø ...17mm): PowerTaron 2140, 4110 and 4140 (two heat sinks) 4x M40 (Ø14...28mm), 2x M32 (Ø12...21mm), 1x M25 (Ø8...17mm)				
Weight	9 kg	10 kg	9 kg	10kg	10 kg
Dimensions	330/360x330x190mm				
Type of protection	IP65				
max load current / time for all types at 20°C					

12.2 regulation data

Valid for 25°C

End of charge voltage	programmable 13.0 .. 14.5V default 13.7V
boost charging	programmable 14,0V...15,0V; 00:30 to 05:00 hours after SOC<70% default 14,4V; 2 h
equal charging	programmable 14,0V...15,5V; 00:30 to 05:00 h after SOC<40% default 14,7V; 2 h
Low voltage disconnect for SOC and (voltage) regulation	programmable 20%...70% (11,0V-11,7V) default SOC< 30% (11,1V)
Load reconnect	programmable 40%...90% (11,9V-13,3V) default SOC> 50% (12,0V)
Charging procedure	IU-curve with PWM at 20Hz
low voltage indication	< 10,5V
high voltage indication	> 15,2V or 0,2V> max. equal charge
high temperature indication	75°C inside case, reset at 65°C

13 Malfunctions and errors

The controller is designed for many years of constant use. Nevertheless, there may be faults. It is very often, however, that the causes for these faults and errors do not occur by the controller itself, but in the peripheral system components. The following description should be used as a helpful guidance to find the sources of malfunctions and to put the device into operation as soon as possible so that unnecessary costs can be avoided. Certainly not all errors are listed below. You will find the most common errors and faults covering the biggest part of all those possible. Send in the controller only when you are sure that none of the below-described errors has occurred.

The system controller is protected against damage by various measures. Nevertheless apply utmost care to the proper operation of the controller. Parts of the malfunctions are indicated with the help of the LCD display. However, only errors are indicated for which the system has been properly installed. If there are other malfunctions as the ones described below please check first of all if the controller has been connected to the accumulator, the module and the loads correctly in the right polarity. Afterwards check the circuit breakers. In case of malfunction the controller switches off the load.

Error	Meaning	Remedy
CB is off	Wrong polarity at the accumulator	<ul style="list-style-type: none"> Switch the circuit breaker on (push down and then up)
No LC-display	<ul style="list-style-type: none"> - battery CB is switched off - actual temperature is too high or too low - external distortions interrupted the LCD controller 	<ul style="list-style-type: none"> Check the working temperature Press the three left keys (▼+▲+ok) together to reset the display.
Module current	The module current exceeds the max. currents allowed. Although this will not cause a defect, the heat sink will become very hot and could cause injury. The load is disconnected in order to avoid further losses and self-heating. After the current has decreased the load will be reconnected automatically	<ul style="list-style-type: none"> The solar generator exceeds the nominal currents. The system must be splitted into smaller generator units.
Load current	The load current is too high and the output is disconnected. Either the whole consumption exceeds the max. discharge currents or the max. pulse currents were exceeded by using powerful consumers A short circuit has been caused. After the problem has been solved the controller reconnects the load after 30 seconds.	<ul style="list-style-type: none"> Switch off some consumers by hand Clear the short cut
Over temperature	The temperature inside has been exceeded. In order to reduce the loss of power the consumer are disconnected automatically. If the controller has cooled down this measure will be revised.	<ul style="list-style-type: none"> Check the ventilation Protect the controller from direct sun
High voltage	In particular the recharge process through back up generators causes voltages, which are harmful for some consumers. Therefore these are disconnected.	<ul style="list-style-type: none"> Disconnect external chargers Check batterycables and the fuse
Low voltage	To protect the battery all consumers influenced by the controller will be disconnected. They will be reconnected automatically after they have reached the load reconnecting level.	<ul style="list-style-type: none"> Connect all consumers through the controller to avoid strong discharge
no modul	No module is connected (theft control) or blocking diods installed (this detection needs 15-60 min !)	<ul style="list-style-type: none"> Check contacts and junctions Paralel blocking diods with 20 kOhm

EEProm Error	The EEPROM of the controller cannot be read or described any longer. Remedy: interrupt the controller's supply of voltage and reconnect it again. If the error cannot be cleared, please see your authorised dealer	<ul style="list-style-type: none"> • Disconnect the charge controller and reconnect it in the order described. If the indication remains, the controller must return to the dealer for repair.
self test failure	The self-test could not have been carried out correctly, since the solar generator or the load had not been disconnected. On of the power components or any other does not function	<ul style="list-style-type: none"> • Disconnect module and load • If the self-test still failed, the controller should be sent to the producer.
Night	"night" message during the day no "night" message during night	<ul style="list-style-type: none"> • Module polarity wrong • Parallel blocking diodes with 20 kOhm

14 Legal Guarantee

In accordance with German statutory regulations, there is a 2-year legal guarantee on this product for the customer.

The seller will remove all manufacturing and material faults that occur in the product during the legal guarantee period and affect the correct functioning of the product. Natural wear and tear does not constitute a malfunction. Legal guarantee does not apply if the fault can be attributed to third parties, unprofessional installation or commissioning, incorrect or negligent handling, improper transport, excessive loading, use of improper equipment, faulty construction work, unsuitable construction location or improper operation or use. Legal guarantee claims shall only be accepted if notification of the fault is provided immediately after it is discovered. Legal guarantee claims are to be directed to the seller.

The seller must be informed before legal guarantee claims are processed. For processing a legal guarantee claim an exact fault description and the invoice / delivery note must be provided.

The seller can choose to fulfil the legal guarantee either by repair or replacement. If the product can neither be repaired nor replaced, or if this does not occur within a suitable period in spite of the specification of an extension period in writing by the customer, the reduction in value caused by the fault shall be replaced, or, if this is not sufficient taking the interests of the end customer into consideration, the contract is cancelled.

Any further claims against the seller based on this legal guarantee obligation, in particular claims for damages due to lost profit, loss-of-use or indirect damages are excluded, unless liability is obligatory by German law.

15 Accessories

Current sensor 200A	PA HS200
Power line receiver	PA 15
Load relais 200A	PA EV200
Battery temp.sensor	PA TS10 (included)
Data logger	TarCom (opt. GSM modem, ethernet)

